



**Heritage
Advisory Committee
Meeting Agenda**

**Monday, February 3, 2020
7 p.m.**

**Holland Room
Aurora Town Hall**

Public Release
January 27, 2020



**Town of Aurora
Heritage Advisory Committee
Meeting Agenda**

Date: Monday, February 3, 2020

Time and Location: 7 p.m., Holland Room, Aurora Town Hall

1. Approval of the Agenda

Recommended:

That the agenda as circulated by Legislative Services be approved.

2. Declarations of Pecuniary Interest and General Nature Thereof

3. Receipt of the Minutes

Heritage Advisory Committee Meeting Minutes of December 9, 2019

Recommended:

That the Heritage Advisory Committee meeting minutes of December 9, 2019, be received for information.

4. Delegations

5. Matters for Consideration

**1. HAC20-001 – Major Heritage Permit Application
15032 Yonge Street (Elmwood Lodge: The Reuben J. Kennedy
House)
File: HPA-2019-07**

Recommended:

1. That Report No. HAC20-001 be received; and
2. That the Heritage Advisory Committee's comments regarding Major Heritage Permit Application File: HPA-2019-07 be referred to staff for consideration and action as appropriate.

**2. HAC20-002 – Minor Heritage Permit Application
80 George Street
File: HPA-2019-06**

Recommended:

1. That Report No. HAC20-002 be received; and
2. That the Heritage Advisory Committee's comments regarding Minor Heritage Permit Application File: HPA-2019-06 be referred to staff for consideration and action as appropriate.

**3. HAC20-003 – Draft Terms of Reference for the Review of the Town's
Register of Properties of Cultural Heritage Value or Interest**

Recommended:

1. That Report No. HAC20-003 be received; and
2. That the Committee review and comment on the Draft Terms of Reference for the comprehensive review of the Town's Register of Properties of Cultural Heritage Value or Interest.

6. Informational Items

4. Memorandum from Planner

Re: Alterations to a Listed Heritage Property – 46 Mosley Street

Recommended:

1. That the memorandum regarding Alterations to a Listed Heritage Property – 46 Mosley Street be received for information.

7. Adjournment



**Town of Aurora
Heritage Advisory Committee
Meeting Minutes**

Date:	Monday, December 9, 2019
Time and Location:	7 p.m., Holland Room, Aurora Town Hall
Committee Members:	Neil Asselin, Jeff Lanthier, Bob McRoberts (Vice Chair), Hoda Soliman, Councillor Sandra Humfryes, James Hoyes (Aurora Historical Society board member on behalf of John Green)
Members Absent:	John Green, Matthew Kinsella
Other Attendees:	Mayor Tom Mrakas (ex-officio), Carlson Tsang, Planner, Linda Bottos, Council/Committee Coordinator

The Vice Chair called the meeting to order at 7 p.m.

1. Approval of the Agenda

**Moved by Hoda Soliman
Seconded by Councillor Humfryes**

That the agenda as circulated by Legislative Services be approved.

Carried

2. Declarations of Pecuniary Interest and General Nature Thereof

There were no declarations of pecuniary interest under the *Municipal Conflict of Interest Act, R.S.O. 1990, c. M.50.*

3. Receipt of the Minutes

Heritage Advisory Committee Meeting Minutes of November 4, 2019

Heritage Advisory Committee Meeting Minutes
Monday, December 9, 2019

Page 2 of 4

**Moved by Neil Asselin
Seconded by Councillor Humfryes**

That the Heritage Advisory Committee meeting minutes of November 4, 2019, be received for information.

Carried

4. Delegations

**Moved by Councillor Humfryes
Seconded by Jeff Lanthier**

That the delegation of Brian Atkins, Architect, representing the Applicant, regarding Item 1 be added to the agenda.

Carried

**(a) Brian Atkins, Architect, representing the Applicant
Re: Item 1 – HAC19-007 – Proposed Consent to Sever and Cultural
Heritage Evaluation Report for 15074 Yonge Street**

Mr. Atkins advised that he has recommended to his client that the property be designated, and he suggested deferring the item until such time that staff have had the opportunity to review details of the recently submitted Cultural Heritage Impact Assessment of the property prepared by the owner's consultant, Mr. Wayne Morgan, Heritage Planner.

**Moved by Councillor Humfryes
Seconded by Hoda Soliman**

That the comments of the delegation be received and referred to Item 1.

Carried

5. Matters for Consideration

Heritage Advisory Committee Meeting Minutes
Monday, December 9, 2019

Page 3 of 4

**1. HAC19-007 – Proposed Consent to Sever and Cultural Heritage
Evaluation Report for 15074 Yonge Street**

Staff confirmed that no permit applications have been received from the owner and there would be no time limitations to consider relative to a deferral of this item. The Committee expressed a preference to discuss the item once the complete information is available for consideration, including staff's review and recommendations on the Cultural Heritage Impact Assessment of the property. The Committee also requested that a tour of the property be arranged for members of the Committee prior to the April 6, 2020 meeting.

**Moved by Hoda Soliman
Seconded by Jeff Lanthier**

1. That Report No. HAC19-007 – Proposed Consent to Sever and Cultural Heritage Evaluation Report for 15074 Yonge Street be deferred to the Heritage Advisory Committee meeting of April 6, 2020.

**Motion to defer
Carried**

**2. Election of Chair and Vice Chair for Year 2020 of the Heritage Advisory
Committee (2018-2022 Term)**

**Moved by Neil Asselin
Seconded by Councillor Humfryes**

1. That Jeff Lanthier be elected as Chair for Year 2020 of the Heritage Advisory Committee (2018-2022 Term).

Carried by acclamation

**Moved by Neil Asselin
Seconded by Councillor Humfryes**

2. That Hoda Soliman be elected as Vice Chair for Year 2020 of the Heritage Advisory Committee (2018-2022 Term).

Carried by acclamation

Heritage Advisory Committee Meeting Minutes
Monday, December 9, 2019

Page 4 of 4

6. Informational Items

None

7. Adjournment

Moved by Neil Asselin

Seconded by Hoda Soliman

That the meeting be adjourned at 7:30 p.m.

Carried



**Town of Aurora
Heritage Advisory Committee Report No. HAC20-001**

Subject: Major Heritage Permit Application
15032 Yonge Street (Elmwood Lodge: The Reuben J. Kennedy House)
File: HPA-2019-07

Prepared by: Carlson Tsang, Planner/Heritage Planning

Department: Planning and Development Services

Date: February 3, 2020

Recommendation

- 1. That Report No. HAC20-001 be received; and,**
- 2. That the Heritage Advisory Committee's comments regarding Major Heritage Permit Application File: HPA-2019-07 be referred to staff for consideration and action as appropriate.**

Executive Summary

This report provides the Heritage Advisory Committee with the necessary information to comment on Major Heritage Permit Application HPA-2019-07 for the removal of ten louvered shutters on a designated building known as ("Elmwood Lodge: The Reuben J. Kennedy House") located at 15032 Yonge Street. Staff recommend the application be deferred pending the review of a damage assessment report prepared by a qualified professional to assess the condition of the shutters and explore potential repair option. If the shutters are demonstrated to be irreparable, it must be replaced in accordance with the provisions set out in the Town's Heritage Property Standard By-law 5489-13.

Background

15032 Yonge Street is approximately 1,221.2 m² (13,144.88 ft²) in size and is located at the north-west intersection of Yonge Street and Kennedy Street West, south of Wellington Street (See Attachment 1). The existing building on the property known as the "Elmwood Lodge: The Reuben J. Kennedy House" was designated in 2006 under Part IV of the Ontario Heritage Act. The Reuben J. Kennedy House is a fine example of a late 19th century, L-shaped house built with the influence of the Gothic Revival style. The property contains 16 surface parking spaces with vehicular access from Kennedy Street West.

History of the Property

The subject property was originally a small section of 210 acres of lands owned by William Kennedy Senior, a member of a prominent family in Town. In 1855, the Kennedy family began subdividing the land. William Kennedy Junior (the third son) acquired the north 100 acres of lands. In 1876, William Kennedy Junior subdivided the land into forty lots on Yonge Street while retaining Lot 40 and part of Lot 39 and constructed the building that currently exists on the subject property.

In 1886, Andrew Yule, an accountant with a family of eight, purchased the property. Yule also served as Town reeve between 1884 and 1888 and was employed as the office manager of the Fleury foundry. The property was held by Yule for over forty years until it was sold to Fleda McQuade in 1934 who converted the building into four apartments and named it "Elmwood Lodge". In 1979, Richard and Anne Allan purchased the property and converted the building into a photography studio and bridal gallery. The property is now owned by Three Small Rooms Restaurant, Bar & Grill, Fine Dining Inc. The building is currently vacant and under renovation. (See Attachment 3 for more historical information about the subject property).

Architectural Features

Elmwood Lodge can be described as a L-shaped two-storey building constructed with the solid light yellow brick. The building features the asymmetry of the Picturesque Revivals of the late 1800s, with a projecting wing attached to the right end of the rectangular body. Gable roofs cover both portions, steeply-pitched on the wing and moderately-pitched on the body. The eaves of the gable roofline are supported by decorative Italianate brackets. Gothic Revival detailing is found in the carved bargeboard and pendant located at the apex of the gable. The main entrance is protected by a two-storey verandah enclosed in the upper floor with bellcast gable roof. A portion of the lower verandah is glassed in to house a commercial display for the business located on the premises. There is a semi-elliptical bay window on the ground floor to the right of the entry. The building is built with sash windows set in semi-circular openings and flanked by louvred shutters.

In 2017, a two-storey addition was constructed at the south west corner of the building. The addition is approximately 63 m² (678.12 ft²) in size with board and batten siding. The addition contains double-hung sash windows to match the original character of the building. There is a porch on the west side with two wooden columns to support the second storey overhang.

Heritage Designation

In 2006, Council adopted By-law 4845.06.R to designate 15032 Yonge Street under Part IV of the Ontario Heritage Act. By-law 4845.06.R. identifies a number of attributes that contribute to the heritage value of the property to be protected:

Exterior Elements

- Overall two storey L-shaped form;
- Projecting wing;
- Gable roofs;
- Asymmetrical façade;
- Window openings and surrounds, and louvered shutters;
- Two storey verandah, enclosed on upper storey with bellcast sides, and covered in shingles
- Main entrance in intersection of 'ell', including sidelights and transom
- Decorative brickwork, including plinth and angled voussoirs;
- Brackets;
- Bargeboard;
- Chimney

Ontario Heritage Act

The *Ontario Heritage Act* provides municipalities the ability to protect significant Cultural Heritage Resources within its jurisdiction. Conservation measures under the *Ontario Heritage Act* are outlined in Section 33 of the *Act as noted below*:

"No owner of property designated under section 29 shall alter the property or permit the alteration of the property if the alteration is likely to affect the property's heritage attributes, as set out in the description of the property's heritage attributes that was required to be served and registered under subsection 29 (6) or (14), as the case may be, unless the owner applies to the council of the municipality in which the property is situate and receives consent in writing to the alteration."

Municipal processes within the Town of Aurora require the owner to submit a Heritage Permit application to alter a designated property under Section 33 of the *Ontario Heritage Act*. Alterations to any attributes identified in the by-law will be considered major and will require approval by Council. Council must make a decision on a major heritage permit application within 90 days after the notice of receipt is served on the applicant, otherwise Council shall

be deemed to have consented the application. Council may defer the application if additional time is required to complete the review of the application.

Minor alterations such as replacement of minor architectural elements may be approved by Staff via Delegation By-law 6212-19.

Analysis

On November 18, 2019, the applicant submitted an application to allow the removal of ten exterior louvered shutters on the Reuben J. Kennedy House due to their deteriorating condition. The shutters proposed to be removed are specifically identified as an attribute to be protected in Designation by-law 4845.06.R, and therefore the proposed work is considered a major heritage permit application as defined in Delegation By-law 6212-19 and will require Council's consent. Council must make a decision on this application by February 16, 2020 as per the prescribed 90 day time frame.

The building contains a total of twelve exterior wooden louvered shutters, six on the east facade facing Yonge Street and six on the south facade facing Kennedy Street. They were all functional (non-decorative) shutters hinged at the window jamb and could be closed to cover the window openings. The shutters are designed with a curved top rail and painted in beige to match the bricks of the building. Staff conducted a site visit and noticed that the shutters are showing varying conditions as described below (See Attachment 2 for photos):

Shutters #	Location	Condition
1	Side window behind the display window on the east elevation facing Yonge Street	- Both shutters are generally in good condition with minimal damages on the stile and mid rail.
2	Bay window on the east elevation facing Yonge Street	- The left shutter is in good condition with minor peeled paint on several slats. - The right shutter is in good condition with minor damages mainly on the bottom rail.
3	Window above the bay window on the east elevation facing Yonge Street	- The left shutter has severe damages on the stiles and a number of slats. - The right shutter has fallen off the building due to broken hinges.

4	Bay window on the south side façade facing Kennedy Street	<ul style="list-style-type: none">- The applicant removed the left shutter in August 2019 due to severe deterioration.- The right shutter has moderate to severe damages on the left stile, push rod and slates
5	Top left window above the bay window on the south elevation facing Kennedy Street	<ul style="list-style-type: none">- Both shutters are in poor condition with severe rotten woods and broken parts.
6	Top right window above the bay window on the south façade facing Kennedy Street	<ul style="list-style-type: none">- Both shutters are in poor condition with severe rotten woods and broken parts.

Section 13.3 i) of the Town's Official Plan indicates that protection, maintenance and stabilization of existing cultural heritage attributes and features over removal or replacement will be adopted as the core principle for all conservation projects. Based on physical evidence, the damage on some of the shutters may be repairable by replacing specific parts such as the rails, slats and stile. Efforts should be made to repair the shutters where possible to preserve the original elements of the building as per Official Plan policy. Staff recommend that the application be deferred to allow the applicant to retain a qualified professional to assess the condition of the shutters and explore potential repair options. The owner may be eligible to apply for a grant through the Building Restoration, Renovation and Improvement Program under the Aurora Promenade Community Improvement Plan to assist with the repairing of the shutters.

In the event that the shutters are demonstrated to be irreparable, they must be replaced in accordance with the requirements set out in Section 5.15.1 of the Town's Heritage Property Standard By-law 5489-13 as noted below:

- (a) *using the same types of material as the original;*
- (b) *where the same types of material as the original are no longer available, using alternative materials that replicate the design, colour, texture, grain, or other distinctive features and appearance of the original material; and*
- (c) *in such a manner as to replicate the design, colour, texture, grain, and other distinctive features and appearance of the Heritage Attribute."*

February 3, 2020

Page 6 of 7

Report No. HAC20-001

Legal Considerations

N/A

Financial Implications

N/A

Communications Considerations

N/A

Link to Strategic Plan

The conservation of heritage resources supports the Strategic Plan goal of ***Supporting an Exceptional Quality of Life for All*** through its accomplishment in satisfying requirements in objective ***Celebrating and Promoting our Culture***.

Alternative(s) to the Recommendation

- 1) That Heritage Advisory Committee provide direction.

Conclusions

The existing building on the subject property known as the “Elmwood Lodge: The Reuben J. Kennedy House” was designated in 2006 under Part IV of the Ontario Heritage Act. The applicant is proposing to remove the exterior louvered shutters on the building, which requires Council’s consent because the shutters are specifically identified as a heritage attribute to be protected in By-law 4845.06.R. Staff recommend the application be deferred pending the review of a damage assessment report prepared by a certified professional to assess the condition of the shutters and explore repair option. In the event that the shutters cannot be repaired, they must be replaced in accordance with the provisions set out in the Town’s Heritage Property Standard By-law 5489-13.

February 3, 2020

Page 7 of 7

Report No. HAC20-001

Attachments

Attachment 1 – Location Map
Attachment 2 – Photographs
Attachment 3 – Heritage Brief

Previous Reports

None.

Pre-submission Review

Agenda Management Team review on January 16, 2020

Departmental Approval

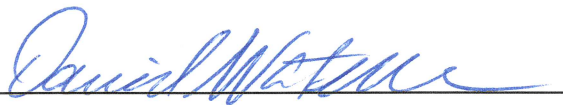

**David Waters, RPP, MCIP, PLE
Director
Planning and Development Services**

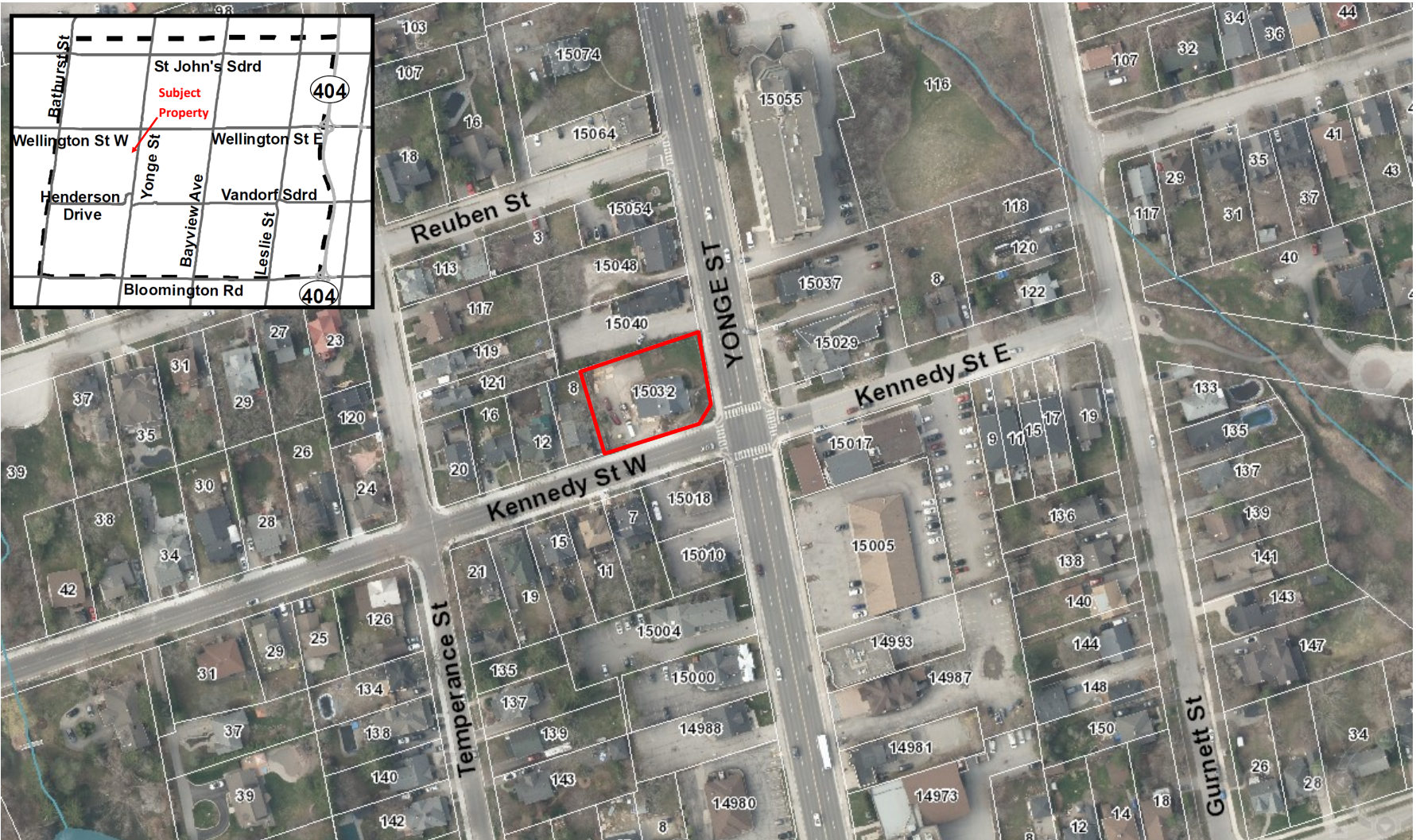

LOCATION MAP

APPLICANT: Three Small Rooms Restaurant, Bar & Grill, Fine Dining Inc.

LOCATION: 15032 Yonge Street

FILE: HPA-2019-17

ATTACHMENT 1

 SUBJECT LANDS

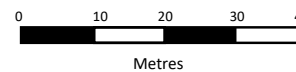

Attachment 2



Shutters # 1

Location: Side window behind the glass display on the east elevation facing Yonge Street.



Condition: Both shutters are generally in good condition with minimal damages on the stile and mid rail.

Left Shutter



Right Shutter



Shutters # 2

Location: Bay window on the east elevation facing Yonge Street.

Condition: The left shutter is in good condition with minor peeled paint on several slats.

The right shutter is in good condition with minor damages mainly on the bottom rail.

Left Shutter



Right Shutter



Shutters # 3

Location: Window above the bay window on the east elevation facing Yonge Street

Condition: The left shutter has severe damages on the stiles and a number of slates.

The right shutter has fallen off the building due to broken hinges. It has moderate damages on most of the slates.

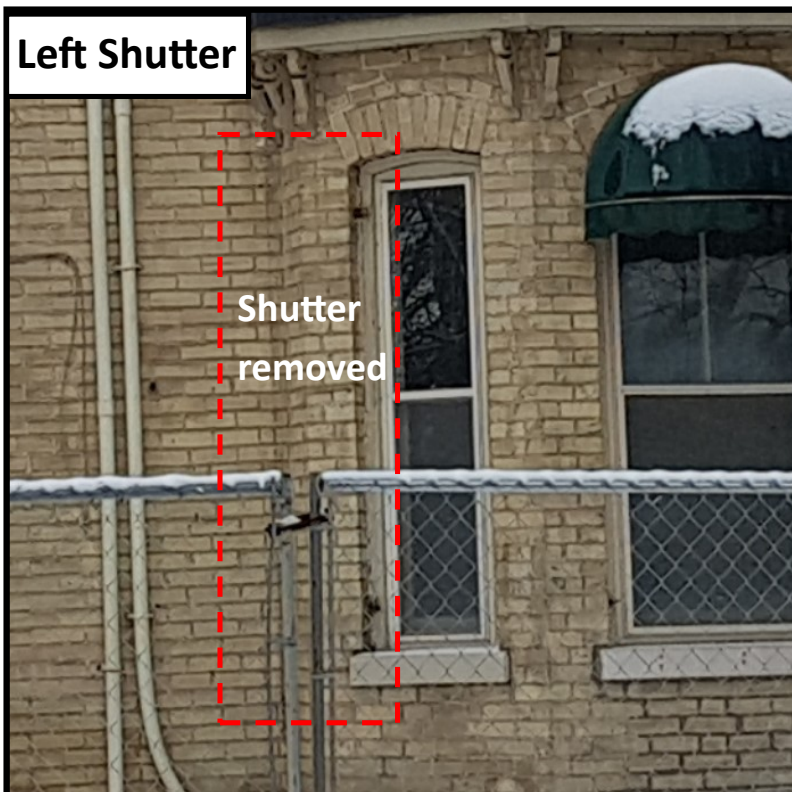

Shutters # 4

Location: Bay window on the south elevation facing Kennedy Street.

Condition: The applicant indicates the left shutter was removed in August 2019 due to severe deterioration.



The right shutter has moderate damages on the left stile, push rod and many of the lower slates.

Left Shutter



Right Shutter



Shutters # 5

Location: Top left window above the bay window on the south elevation facing Kennedy Street.

Condition: Both shutters are in poor condition with severe rotting wood and broken parts.



Shutters # 6

Location: Top right window above the bay window on the south elevation facing Kennedy Street.

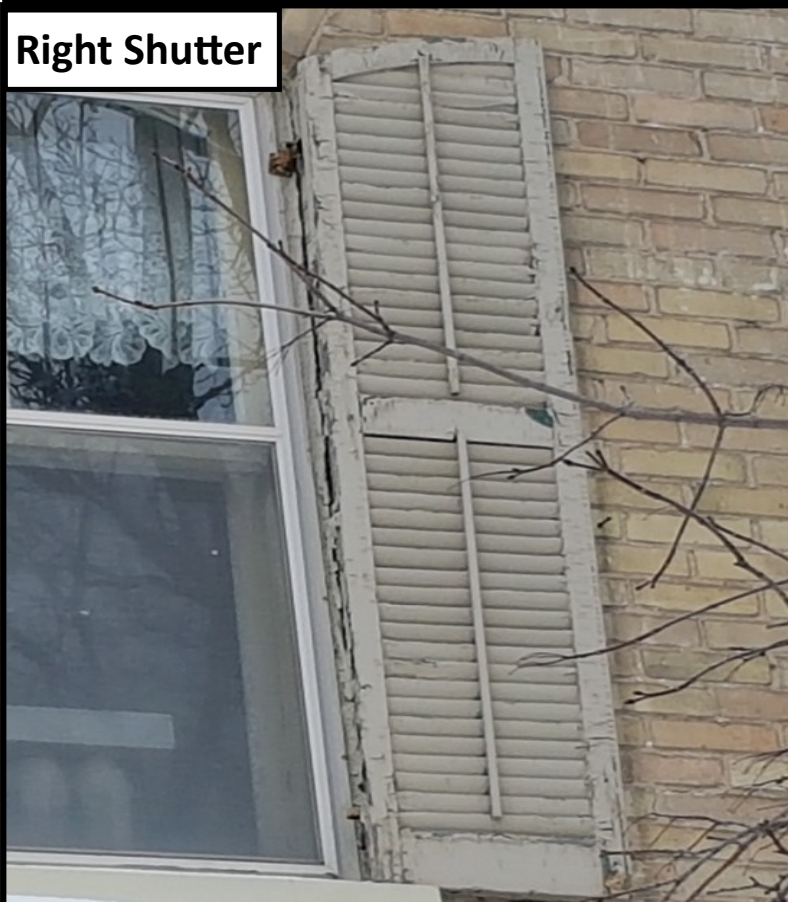

Condition: Both shutters have moderate to severe damages on the rail and stile.

Attachment 3

[Town of Aurora crest]

HERITAGE PROPERTY REPORT



1977

ELMWOOD LODGE

PROPERTY: Elmwood Lodge

ADDRESS: 124 Yonge Street South
Plan 39. Part Lots 39 and 40 Town of Aurora
Regional Municipality of York

CONSTRUCTION DATE: Circa 1870-80

ORIGINAL OWNER: Reuben J. Kennedy, Farmer

PRESENT OWNER: Richard Allan, Photographer,
and Associates

124 Yonge Street South, Auroral

HISTORICAL BACKGROUND:

This property represents a small section of former Township Lot 79, consisting of 210 acres of land received by William Kennedy, Sr., in a Crown Patent dated 1803. William Kennedy, Jr., and other relatives began subdividing the acreage in 1855. Reuben J. Kennedy acquired the north half, or 100 acres, of Lot 79 when other family heirs surrendered their claims to him.

R. J. Kennedy was born in Aurora in 1837 as the third son of William Kennedy, Sr. He moved to British Columbia in 1862 to participate in the gold rush and did not return to the village until 1869. The substantial solid brick residence probably was constructed during the 1870s.

It is possible that the structure was not erected until 1876 when the *Aurora Banner* announced that the Kennedy estate had been divided into forty building lots on Yonge, Kennedy and Reuben streets to be offered for sale by public auction.* Lot 40 and part of Lot 39 were retained by R. J. Kennedy. He and his wife, Harriet (born 1849), moved to Toronto with their six children in 1891, although they continued to hold property in the town.

In 1886, Andrew Yule (born 1840 in Scotland), an accountant with a family of eight, purchased the site. Yule, who served as town reeve between 1884 and 1888, was employed as the office manager of the Fleury foundry and briefly ran the plant after Joseph Fleury died in 1880.

Fleda McQuade, who bought the house in 1934, held the property for forty-five years; the dwelling received its name during her tenure. The current owners have converted the house for combined professional, commercial and residential uses.

* Although a subdivision may have been surveyed at this time, an official plan was not registered until 1886. R. J. Kennedy is listed as a 'farmer' by occupation in the 1881 census; however, his main interest appears to have been in the development of the family lands.

HISTORICAL SIGNIFICANCE:

The substantial dwelling house has had relatively few owners in over one hundred years since the site was developed. The property was occupied for a decade by Reuben J. Kennedy, member of a prominent founding family, who built his residence on a parcel of the family estate while establishing the basis for a late-nineteenth-century subdivision on the adjacent acreage.

Andrew Yule, the next owner and a well-known local figure, and members of his family held the site for over forty years.

The house is associated locally with Fleda McQuade (only the fourth owner) who retained the property, known as Elmwood Lodge, for nearly half a century. Its adaptation for commercial purposes in recent years marks a growing trend in the neighbourhood.

ARCHITECTURAL SIGNIFICANCE:

Elmwood Lodge is a substantial L-shaped farmhouse, a vernacular building type that was readily transformed from rural to urban settings in the late nineteenth century. Constructed in the solid light yellow brick used in other dwellings found throughout Aurora, the house incorporates features from a variety of architectural styles of the period.

The sprawling two-storey structure embodies the asymmetry of the Picturesque Revivals of the late 1800s, with a projecting wing attached to the right end of the rectangular body. Gable roofs cover both portions, steeply-pitched on the wing and moderately-pitched on the body. The main entrance, characteristically placed at the intersection of the ell, is protected by a two-storey verandah enclosed in the upper floor.

To the right of the entry, the facade of the wing is dominated by a semi-elliptical bay window in the ground floor. Directly above, a single opening embellished with a radiating brick voussoir visually appears to rest on the hipped roof of the bay. The extended eaves of the open gable roofline are supported by decorative Italianate brackets, repeated on the bay window. Gothic Revival detailing is found in the carved bargeboard and pendant located at the apex of the gable. This treatment of the wallspace is duplicated on the south elevation flanking Kennedy Street West*; the wider body accommodates two windows in the upper floor. The large sliding sash windows throughout the structure are set in semi-circular openings and flanked by louvred shutters. On the north wall, divided midway by a tall, narrow chimney, the window sizes vary according to function.

A 1½-storey solid brick tail contains the kitchen with space overhead. The porches running along either side of this addition were constructed later. While two wooden tails once were situated behind the wing, a single-storey stuccoed attachment now completes the building.

On the Yonge Street facade, the doorway once was sheltered by a single-storey verandah with a hipped roof. The lower edges of the upper verandah (added later) are bellcast to conceal the original roofline, and the whole is covered with wooden shingles and capped by a pedimental roofline, reminiscent of the cold classical detailing of the early 1900s. A portion of the lower verandah is glassed in to house a commercial display for the business located on the premises.

The decorative trim and flared shutters are painted a Prussian blue hue which complements the yellow brickwork. The elegant residence, with its projecting portions and graceful setback, is well-maintained and shown to advantage on a corner lot.

* The south wall lacks decorative bargeboard, which is replaced by a bracket at the apex of the roof.

CONTEXTUAL SIGNIFICANCE:

Elmwood Lodge anchors the south end of a short block of four residences facing east onto Yonge Street between Reuben Street and Kennedy Street West. The large-scale dwelling is separated from its neighbours to the north by a side yard.* While these less pretentious houses are located close to the street (more so since the widening of the roadway) and to one another, the sprawling Kennedy residence enjoys ample room across two lots.** Its light yellow brickwork sets it apart from the white frame and red brick structures in the immediate vicinity.

The presence of Elmwood Lodge on the west side of Yonge Street signifies the beginning of the consistent southerly growth of the town following the systematic division of the Kennedy lands in the closing decades of the nineteenth century. While its plan and decoration are linked to the Pease-Ardill House (113 Yonge) across the street, its situation on the corner of Kennedy Street marks the introduction of the cohesive residential area to the west with the appearance of a series of large brick-clad ‘pattern’ houses. The location of Elmwood Lodge on the busy thoroughfare probably has hastened its conversion (with its neighbours at 120 and 126 Yonge) for commercial use, thereby absorbing a formerly residential enclave into the southern business district of Aurora.

* According to documented sources, a small 1-storey frame structure once was situated on this land between 120 and 124 Yonge. R. J. Kennedy sold this portion of Lot 39 to Philip L. Querrie, a blacksmith and carriage maker, in 1876. The next registered transfer saw Walter Yule selling the site to Watson Yule in 1915.

** In 1946, Fleda McQuade subdivided and sold the rear sections of Lots 39 and 40, with frontage on Kennedy Street West.

ELMWOOD LODGE

APPENDIX I

Sources:

Registry Office Records, York County (Newmarket)

Assessment Rolls, Town of Aurora

Aurora Banner, July 7 and September 29, 1876

1881 Decennial Census

History of Toronto and the County of York (Toronto: C. Blackett Robinson, 1885), pp. 435-444

Fire Insurance Map, 1904, revised 1913

Toronto Globe, obituary of R. J. Kennedy, April 12, 1909

Aurora Banner, obituary of R. J. Kennedy, April 16, 1909

James Johnston, *Aurora: Its early beginnings*, 1963

Aurora LACAC Files: 124 Yonge Street South

Ralph Greenhill, Ken MacPherson, and Douglas Richardson, *Ontario Towns*, 1974

Kim Ondaatje and Lois Mackenzie, *Old Ontario Houses*, 1977



**Town of Aurora
Heritage Advisory Committee Report No. HAC20-002**

Subject: Minor Heritage Permit Application File: HPA-2019-06
80 George Street

Prepared by: Carlson Tsang, Planner/Heritage Planning

Department: Planning and Development Services

Date: February 3, 2020

Recommendation

- 1. That Report No. HAC20-002 be received; and,**
- 2. That the Heritage Advisory Committee's comments regarding Minor Heritage Permit Application File: HPA-2019-06 be referred to staff for consideration and action as appropriate.**

Executive Summary

This report provides the Heritage Advisory Committee with the necessary information to comment on Minor Heritage Permit Application HPA-2019-06 to allow the replacement of three casement windows, two fixed windows and one side entrance door on the south elevation of a designated building known as "The Benjamin Willis House" located at 80 George Street. Staff are of the opinion that the proposed new door and windows are appropriate and will not adversely affect the original heritage character of the building and support the approval of the heritage permit application as submitted.

Background

80 George Street is approximately 697.34 m² (7,506 ft²) in size and is located at the north west corner of the intersection of George Street and Tyler Street, west of Yonge Street and south of Wellington Street West (See Attachment 1). The property contains a two-storey residential dwelling constructed circa 1888, known as the "The Benjamin Willis House", which was designated in 2008 under Part IV of the Ontario Heritage Act. The building is a fine example of a Gothic Revival Style farmhouse built in the 19th Century to house workers and management in local industries like the Fleury Foundry. Vehicular access is currently provided from Tyler Street. Mature vegetation exist across the property including several large mature trees at the front and side yards.

History of the Property

In 1882, Benjamin Willis, a prominent farmer in the community, purchased the subject property and constructed the existing building in 1888 for his retirement. Willis lived in the house for about 10 years and passed away in 1897. Following Willis's death, the property was owned by several prominent figures in the area including Charlie Thom, a retired foreman blacksmith from the Fleury foundry on Wellington Street; and A.A. Conover, a local speculator who at one point owned majority lands on Tyler Street and Hillview Road. In 1912, the property was sold to Jane Stewart. The building was rented to Frank Allen who later moved out and purchased the building known as "The Chateau" on Yonge Street at 15074 Yonge Street with his wife Florence Chadburn.

In 1938, Walter E. Quantz, the mortgagor of the property, acquired the property by means of a quit claim by the Stewarts. The property was sold to William and Eileen Kettlewell in 1945. Kettlewell was a popular artist and a member of the board of the Ontario Heritage Foundation who unveiled the provincial plaque outside the Old Aurora Public School on Church Street. In 1959, the local Baptist congregation purchased the property and used the house as a parsonage for a church near Wellington Street and Victoria Street. During the Baptist church's ownership of the property, the ministers were Rev. R.D. Filyer and Rev. Bruce Moorhouse. The next owners of the property include the Bury family between 1969 and 1979, the Martin family between 1979 and 1994, the Hullah family between 1994 and 2015. (See Attachment 4 for more information about the historical background of the subject property).

Architectural Value

The Benjamin Willis house features local variation of Gothic Revival Style Architecture adapted with the influence of the Arts and Crafts movement in the early 20th Century. The building can be described as an L-shaped building designed with gable roofs and overhanging eaves. The siding material is composed of stucco, and aluminum which was added as part of the side and rear addition constructed in the 1990's. There is a wrap-around porch covering the south east corner of the building including the main entrance facing George Street. The windows are predominately multi-paned (6/1 or 8/1) wooden sash windows with exterior trims and storm sash. There are three casement windows and two fixed windows on the south elevation that are modern in style, which were possibly installed in the 1990's. The building contains multi lite door at the main entrance fronting George Street, and one single glazed panel door at the side entrance fronting Tyler Street.

Heritage Designation

In 2006, Town Council passed By-law 5078-08.R to designate 80 George Street under Part IV of the Ontario Heritage Act. By-law 5078-08.R. identifies the following exterior elements of the building that contribute to the heritage value of the property:

- Stucco Exterior
- South and east gables
- Arts and Crafts exterior;
- Gothic Revival – L Shaped form.
- Historic window and door openings.
- Multi-paned - Wood sash windows and window trim and storm sash;

Ontario Heritage Act

The *Ontario Heritage Act* provides municipalities the ability to protect significant Cultural Heritage Resources within its jurisdiction. Conservation measures under the *Ontario Heritage Act* are outlined in Section 33 of the *Act* as noted below:

“No owner of property designated under section 29 shall alter the property or permit the alteration of the property if the alteration is likely to affect the property’s heritage attributes, as set out in the description of the property’s heritage attributes that was required to be served and registered under subsection 29 (6) or (14), as the case may be, unless the owner applies to the council of the municipality in which the property is situate and receives consent in writing to the alteration.”

Municipal processes within the Town of Aurora require the owner to submit a Heritage Permit application to alter a designated property under Section 33 of the *Ontario Heritage Act*. Alterations to any attributes identified in the by-law will be considered major and will require approval by Council. Council must make a decision on a major heritage permit application within 90 days after the notice of receipt is served on the applicant, otherwise Council shall be deemed to have consented the application. Council may extend the 90 day period if additional time is required to complete the review of the application.

Minor alterations such as replacement of minor architectural elements may be approved by Staff via Delegation By-law 6212-19.

Analysis

On November 18, 2019, the applicant submitted Heritage Permit Application HPA-2019-06 to allow the replacement of five windows (three casement and two fixed) and one side door on the south side of the Benjamin Willis House. Staff consider the proposal a minor heritage permit application because no changes are being proposed to any of the attributes listed in the designation by-law. However, given the proposed work will result in some level of changes to the appearance of the heritage building, staff are of the opinion it should be presented to the Heritage Advisory Committee for information.

Staff conducted a site visit and made notes on the condition of the elements proposed to be replaced as described below (See Attachment 2 for photos):

Elements Proposed to be Replaced	Dimension	Condition
Single glazed panel door with a storm door on the south elevation of the building facing Hillview Road	34" x 80.5" (Door) 38" x 83" (Frame)	<ul style="list-style-type: none">- good physical condition- the glass wobbles when opening and closing the door
Three lit casement windows immediately beside the garage door facing Hillview Road	21.5" x 38" (Each Window) 77" x 44" (Frame)	<ul style="list-style-type: none">- generally in good condition with minor damages on the bottom rail- Windows can be opened smoothly with the operator handle
Two fixed windows on the south elevation facing Hillview Road	23 1/4" x 58 3/4". (Each Window) 28" x 63" (Frame)	<ul style="list-style-type: none">- Good physical condition

Replacement of Door

The historic door openings identified in By-law 5087-08.R. relate to the fenestration of the building, not the physical door. There was very little evidence to suggest that the door contributes to the heritage value of the building and hence it was not included as an attribute in the designation by-law.

The applicant initially proposed a new steel door with a decorative wrought iron glass inserts. Staff expressed concerns because the material is too contemporary in style and the wrought iron glass is overelaborated with inappropriate details that are incompatible with the original character of the building. In response, the applicant is now proposing a solid wooden door designed with two four square-shaped lites on the top and two tall panels on the body (See Attachment 3).

Wood is a more appropriate choice of material that blends in better with the architectural texture of the building. The lites adds interesting elements to the door and align with the details of the two garage doors. The tall panels make the door more vertically proportioned and in keeping with the Gothic Revival style of the building. Staff are of the opinion that the new door will complement the historical appearance of the building and enhance the character of the overall streetscape.

Replacement of Windows

By-law 5087-08.R identifies “Multi-paned - Wood sash windows and window trim and storm sash” as a heritage attribute to be protected. The five windows proposed to be removed on the south elevation do not match the above description because they are casement and fixed windows and are not supplemented with any storm sash. They were possibly installed as part of the addition constructed in the 1990’s and were not identified as being of heritage value to building when the property was designated in 2008.

The applicant initially proposed to install casement windows. No changes are being proposed to the existing window openings. Staff encouraged the applicant to consider multi-paned sash windows instead to match the appearance of the other original windows on the building. In response, the applicant revised their proposal to use 6/1 double-hung sash window as shown in Attachment 3. Staff support the new proposal because sash window is more compatible with the overall appearance of the south façade and will help restore the original heritage character of the building.

Legal Considerations

N/A

Financial Implications

N/A

February 3, 2020

Page 6 of 7

Report No. HAC20-002

Communications Considerations

N/A

Link to Strategic Plan

The conservation of heritage resources supports the Strategic Plan goal of ***Supporting an Exceptional Quality of Life for All*** through its accomplishment in satisfying requirements in objective ***Celebrating and Promoting our Culture***.

Alternative(s) to the Recommendation

- 1) That the Heritage Advisory Committee provide direction.

Conclusions

The applicant is proposing to replace five windows and one side door on the south elevation of a designated building known as “The Benjamin Willis House” located at 80 George Street. Staff are of the opinion that the proposed work is compatible with the heritage character of the existing building and therefore support the approval of Minor Heritage Permit Application HPA-2019-06.

Attachments

- Attachment 1 – Location Map
- Attachment 2 – Photographs of existing building
- Attachment 3 – Notes from Site Visit
- Attachment 4 – Information about the proposed door and windows
- Attachment 5 – Heritage Brief

Previous Reports

None.

Pre-submission Review

Agenda Management Team review on January 16, 2020

February 3, 2020

Page 7 of 7

Report No. HAC20-002

Departmental Approval

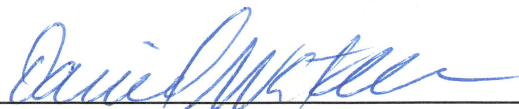

**David Waters, RPP, MCIP, PLE
Director
Planning and Development Services**

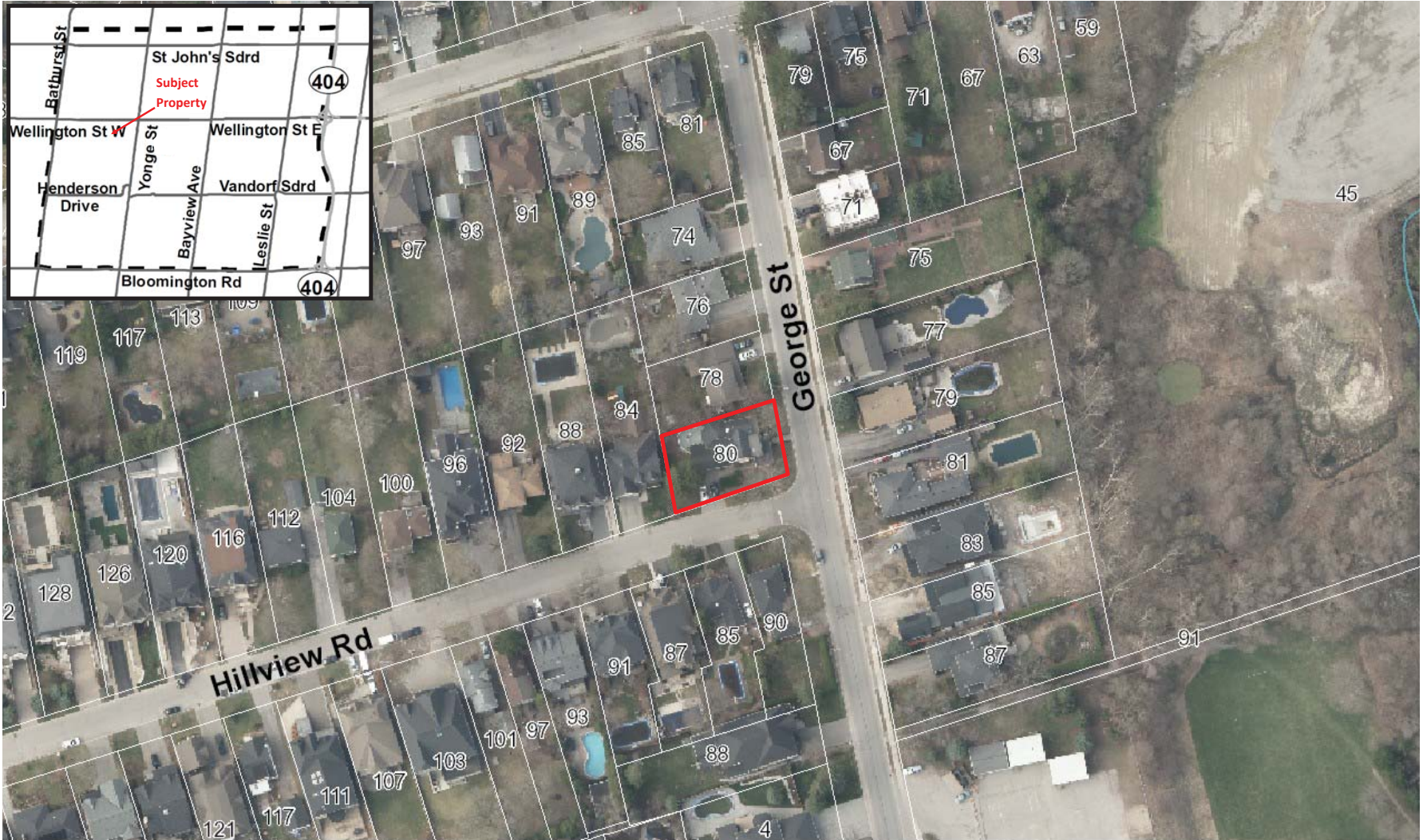

LOCATION MAP

APPLICANT: JUSTIN ROSA
LOCATION: 80 George Street
FILE: HPA-2019-06
ATTACHMENT 1

 SUBJECT LANDS

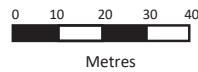

Map created by the Town of Aurora Planning and Building Services Department, January 2020. Base data provided by York Region & the Town of Aurora. Air Photos taken Spring 2018, © First Base Solutions Inc., 2018 Orthophotography.

Attachment 2







Attachment 3



Location and Description:

Single glazed panel door
on the south elevation of
the building.

Dimension:

34" x 80.5" (Door)

38" x 83" (Frame)

Condition:

The door is in good physical
condition. The glass wobbles
when opening and closing
the door.





Location and Description:

three casement windows adjacent to the garage doors .

Dimension:

21.5" x 38" (each window)

77" x 44" (frame)

Condition:

The windows are generally in good condition and can be opened smoothly with the operator handle.



Location and Description: Double fixed windows on the ground floor of the south elevation.

Dimension:
23 1/4" x 58 3/4" (window)
28" x 63" (Frame)

Condition:
Both windows are in very good physical condition.



Attachment 4



Proposed Door

Description:

Wooden door designed with two four squared shaped lits on the top, and two tall panels on the body'

Dimension:

34" x 80.5" (Same as the existing door)

WGF-3300

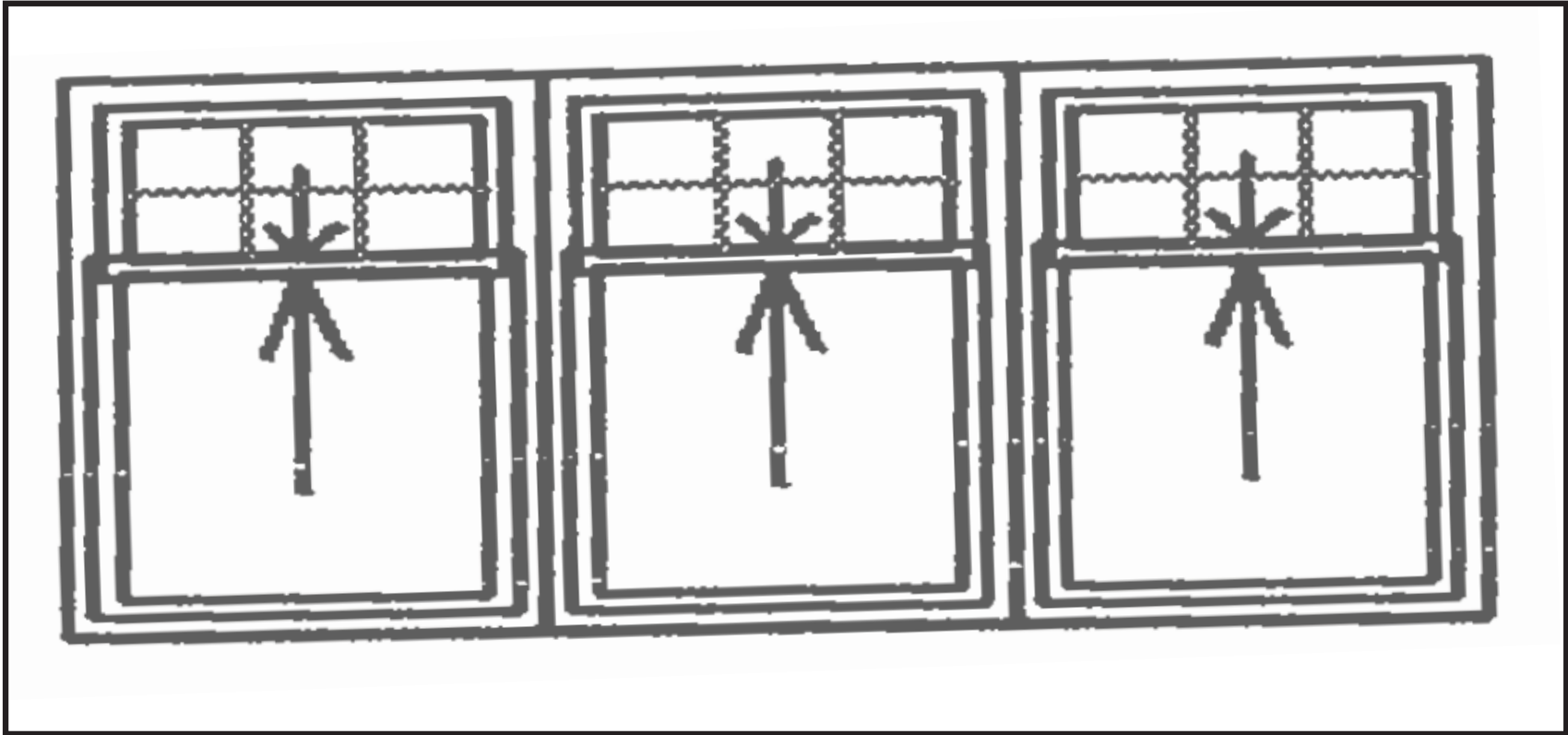

Proposed Windows

Description:

Multi-paned (6/1) double hung windows

Dimension:

21.5" x 38" for each window (same as existing)

Attachment 5

Heritage Designation Brief



The Benjamin Willis House

80 George Street,

Aurora, ON

Built 1888

September 2008

By Michael Seaman, Community Planner

Based on Research by Jacqueline Stuart

HERITAGE DESIGNATION STATUS SHEET

Street Address: 80 George Street
Roll Number: 1946-000-031-70200-0000
Short Legal Description: PLAN 30 PT LOTS 42 & 43
Names of Owners: The Hullah Family
Owners Mailing Address: 80 George Street, Aurora, ON L4G 2S4
Owner's Concurrence: Yes
Heritage Type: House
Designation Type: Section 29, Part IV
Designation Brief Completion Date: August 28, 2008
Heritage Committee Application Approval Date: September 2008
Designation Brief Completed by: Michael Seaman, Community Planner
Submission Date: September 2008
Objections Noted: None
Comments: Owner agreed as part of committee of adjustment
Approval for the site. Site visit determined to be
a significant example of a Victorian L-shaped house

“The statement of Cultural Heritage value or interest, including a description of the heritage attributes along with all other components of the heritage designation report constitute the reason or designation required under the Ontario Heritage Act, the reasons for designation required under the Ontario heritage. The heritage designation report is available for viewing in the Town Clerk’s Office during regular business hours.

Statement of Cultural Heritage Value or Interest

Historical Value

80 George Street has historical value in its association with various prominent families in Aurora over its 120 years of existence.

This house was apparently constructed during the 1888 building season. The assessment roll for 1888—the tax rolls were usually prepared early in the year, or late in the previous year—show that the property was vacant at that time (see attached notes). The low value of the property, \$225, reflects its undeveloped state. By the following year, 1889, the property value had risen to \$1100: the owner, Benjamin Willis, had had a house.

The 1888 construction date is supported by an announcement in the *Aurora Banner* of 23 September 1887: “Mr. Benjamin Willis has purchased two lots on George Street from Mr. Lepper and intends to retire from farming and move into town. He will build in the spring.”

In addition, newspapers from 1888 were found in the house in 1994 [letter in historical society files from owner at that time].

Mr. Willis lived to enjoy his retirement home for some ten years; he died in May of 1897. After living on in the house herself, and then renting it out, Mr. Willis’ widow, Rebecca, sold the property to Charles Thom, a retired foreman blacksmith from the Fleury foundry on Wellington Street. Mr. Thom later moved to Temperance Street, and sold the George Street property to A.A. Conover, a local speculator who at one point owned virtually all of Tyler and Hillview. At that time, and until 1952, the latter street was known as “Lepper” for the local merchant and landowner who had his landholdings in the area subdivided in 1874.

With Mr. Conover’s sale of the property to Mrs. Jane Stewart in 1912 a long tenure of ownership by one family began. For some time Mrs. Stewart had Frank Allen as a tenant. One of Mrs. Stewart’s grandchildren, the late Agnes Stewart Baldwin, described the Allens as cousins of the Stewarts [Agnes Stewart Baldwin, *Memoirs* {unpublished manuscript, 1984, Aurora Museum}] but the exact nature of the relationship has not been determined. Certainly one of Frank Allen’s sons was named Stewart. Frank eventually became the stepfather of Lloyd V. Chadburn, who saw distinguished service in the RCAF during World War II. After their marriage Frank Allen and Florence

Chadburn Allen purchased the house known as The Chateau on Yonge Street, north of Reuben, and ran it for many years as a tourist home. [A long digression!]

By 1925 the house was occupied by one of Jane Stewart's sons, Albert Stewart, and his family: his wife, Gertrude Mae, and their three daughters, Agnes, Marjorie, and Helen. The family had been living in northern Ontario, where Albert Stewart worked for the Department of Lands and Forests. Their last northern home was in Kapuskasing, but they moved south when a new town site for Kapuskasing was established and the old site, including the Stewarts' home, was deliberately razed [Baldwin: *Memoirs*].

The Stewarts mortgaged the George Street property in 1930 and the mortgagor, Walter E. Quantz, acquired it by means of a quit claim by the Stewarts in 1938.

Mr. Quantz does not appear to have lived in the house himself. One of his tenants was Chester C. Macdonald, a young lawyer whose mother was the author Lucy Maud Montgomery, creator of *Anne of Green Gables*. Mr. Macdonald moved into the house in 1940 or 1941, but probably left in 1944 or earlier on the breakdown of his first marriage.

The next owners were William and Eileen Kettlewell, who may have first occupied the property as tenants. They purchased the house in 1945. William Kettlewell was an artist. At a much later date, in 1981, Mr. Kettlewell unveiled the provincial plaque which stands outside the old Aurora Public School on Church Street, in his position as a member of the board of the Ontario Heritage Foundation.

The Kettlewells sold the house and land at George and Hillview in 1948 to George Hoffman, a chemist and manufacturer, and his wife Dottie (officially, Honora Frances). Four years later it was passed to the Hoffmans' only child, Frances E. Miller, but the parents still lived in the house. Mr. Hoffman died at home in 1958 [*Aurora Banner*, 16 January 1958].

The local Baptist congregation purchased the George Street property in 1959, for use of the house as a parsonage and possibly for the eventual use of the adjacent building lots: the church needed a new building. For a time it was planned to sell the church property at Wellington and Victoria and build anew on George Street. However, as there was a good deal of outside interest in the building lots on George and Hillview, and none in the site at Wellington and Victoria, it was decided to rebuild on the existing church site. The sale of the adjoining vacant lands began in the early 1960s and the George Street parsonage was sold in 1969. During the Baptist church's ownership of the George Street house, the ministers were Rev. R.D. Filyer (1960–1965) and Rev. Bruce Moorhouse (1966–1971) [*First Baptist Church, Aurora, Ontario, 1883-1983; church history*].

From 1969 until 1979 the Bury family owned number 80 George Street, and from 1979 until at least 1994 the Martin family.

The house is currently owned and occupied by the Hullah family.

Architectural Value

The house at 80 George Street has architectural value as a local variation of Gothic Revival Style Architecture that was adapted with Arts and Crafts influence at the The house at 80 George Street is a classic example of the a modest Gothic Revival influenced L-shaped Home with its asymmetrical façade, north gable and 1 ½ storey form.

Contextual Value

80 George Street is prominently located midway along on George Street in the vicinity of other historic homes. This house and others nearby help to create a sense of heritage character in this part of Old Aurora.

SUMMARY OF HERITAGE ATTRIBUTES TO BE DESIGNATED

The reasons for designation include the following heritage attributes and apply to all elevations and the roof including all facades, entrances, windows, chimneys and trim together with construction materials of wood, brick stone, plaster parging and glazing, their related building techniques and landscape features.

Exterior Elements

- **Stucco Exterior**
- **South and east gables**
- **Arts and Crafts exterior;**
- **Gothic Revival – L Shaped form.**
- **Historic window and door openings.**
- **Multi-paned - Wood sash windows and window trim and storm sash;**



Subject: Draft Terms of Reference for the Review of the Town's Register of Properties of Cultural Heritage Value or Interest

Prepared by: Carlson Tsang, Planner

Department: Planning and Development Services

Date: February 3, 2020

Recommendation

- 1. That Report No. HAC20-003 be received; and,**
- 2. That the Committee review and comment on the Draft Terms of Reference for the comprehensive review of the Town's Register of Properties of Cultural Heritage Value or Interest.**

Executive Summary

The purpose of this report is to present the Heritage Advisory Committee with a draft Terms of Reference (TOR) for the comprehensive review of the Town's heritage register prior to issuing the Request for Proposal (RFP) and retaining a consultant team. This report provides an overview of the TOR, highlighting key elements such as the objectives and overall process of the project.

Background

The *Ontario Heritage Act* gives municipalities the authority to maintain a register that contains properties of significant heritage value, known as the Register of Properties of Cultural Heritage Value or Interest. The intent of this register is to serve as a heritage conservation tool to assist municipalities in identifying and conserving heritage resources.

The Town of Aurora's Heritage Register contains 48 individually designated properties (Part IV), 148 properties within the Northeast Old Aurora Heritage Conservation District (Part V), and 413 listed properties. The majority of the listed properties had not been subject to a heritage evaluation and remain on the register without any heritage score or classification. The lack of information about their heritage value makes it difficult for the Town to determine if they warrant designation for greater degree of protection under the Ontario Heritage Act.

On November 12, 2019, Council approved the 2020 capital budget that includes a project for the procurement of consultant services to undertake a comprehensive review of the Town's heritage register. This a multi-year project and will focus on the following key objectives:

- Determine the level of heritage importance of each listed property on the register in order to prioritize future conservation efforts and preservation programs.
- Identify those properties of significant cultural heritage value and pursue designation for their long-term protection under the Ontario Heritage Act.
- Update the register with more complete information, and remove irrelevant properties

The Draft Terms of Reference for the project is attached to this report for the Committee's review. The project will consists of four phases as follows:

Phase 1 - Data Collection

Phase 2 - Preparation of Cultural Heritage Evaluation Reports

Phase 3 - Consultation with Heritage Advisory Committee and Council

Phase 4 - Heritage Designation, Delisting and Updates to the Register

Legal Considerations

None.

Financial Implications

Council has approved a 2020 capital budget which includes the procurement of consultant services to undertake a comprehensive heritage assessment of the Town's register at a total estimated cost of \$100,000. A Request for Proposal (RFP) is included in the Terms of Reference to outline submission requirements and evaluation criteria as it relates to the required consulting services. This is expected to be a multi-year project. Additional funding, subject to Council's approval, may be required should the preferred proposal exceed the approved capital budget of \$100,000.

February 3, 2020

Page 3 of 4

Report No. HAC20-003

Communications Considerations

None.

Link to Strategic Plan

The comprehensive review of the Town's Heritage Register supports conservation of heritage resources which contributes to the Strategic Plan goal of ***Supporting an Exceptional Quality of Life for All*** through its accomplishment in satisfying requirements in objective ***Celebrating and Promoting our Culture***.

Alternative(s) to the Recommendation

None.

Conclusions

A comprehensive review of the register is warranted in order to create a more effective heritage inventory to assist the Town in the management and protection of its heritage resources. The Town is proposing to retain a qualified consultant to undertake this project. A draft terms of reference has been prepared to establish the project's objectives, process, deliverables, expectations and requirements. Staff are seeking the input of the Committee on the Terms of Reference prior to presenting it to Council for endorsement.

Attachments

Attachment 1- Draft Terms of Reference

Previous Reports

None.

Pre-submission Review

Agenda Management Team review on January 16, 2020

February 3, 2020

Page 4 of 4

Report No. HAC20-003

Departmental Approval

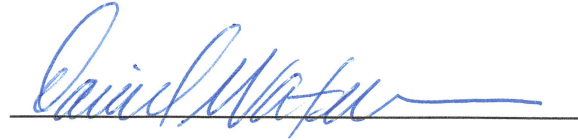

**David Waters, MCIP, RPP, PLE
Director
Planning and Development Services**

DRAFT

Attachment 1

TERMS OF REFERENCE

February 2020



**Review of Aurora
Register of Properties of
Cultural Heritage Value
or Interest**

Draft Terms of Reference
Review of Aurora Register of Properties of Cultural Heritage Value or Interest

Table of Contents

1.0	INTRODUCTION	3
2.0	PROJECT OVERVIEW	3
3.0	PROCESS	4
3.1	Phase 1 - Data Collection	4
3.2	Phase 2- Cultural Heritage Evaluation Report (CHER).....	4
3.2.1	Deliverables for Phase 2	5
3.3	Phase 3 – Consultation with Heritage Advisory Committee and Council	6
3.4	Phase 4 – Heritage Designation, Delisting and Update to the Register	6
3.4.1	Deliverables for Phase 4	6
4.0	TIMING	7
5.0	ROLES AND RESPONSIBILITIES	7
5.1	Steering Committee	7
5.2	Town Staff (Planning Division).....	7
5.3	Consultant	7
6.0	REQUEST FOR PROPOSAL	8
6.1	Required Proposal Format.....	8
6.2	Interviews.....	8
6.3	Selection and Awarding of Contract.....	9
6.4	Submission Deadline	9

Draft Terms of Reference
Review of Aurora Register of Properties of Cultural Heritage Value or Interest

1.0 INTRODUCTION

The *Ontario Heritage Act* allows municipalities to maintain a publicly accessible register, known as the Register of Properties of Cultural Heritage Value or Interest, to help manage the conservation of local cultural heritage resources. The register includes a list of properties that are designated under Part IV (individual designation) and Part IV (within a Heritage Conservation District) of the Ontario Heritage Act, and non-designated properties that have been listed as being of potential cultural heritage value or interest to the community. The Town of Aurora's register consists of 48 individually designated properties, 148 properties within the Northeast Old Aurora Heritage Conservation District, and 413 listed properties.

The properties on the register were originally identified in the Town's first official inventory prepared by the Local Architectural Conservation Advisory (now known as the Heritage Advisory Committee) between 1976 and 1987. The inventory was compiled through a windshield survey, which targeted buildings constructed prior to the Second World War that exhibited some degree of architectural and/or historical significance.

In September 2006, Aurora Town Council officially changed the name of the Aurora Inventory of Heritage Building to the "Aurora Register of Property of Cultural Heritage Value or Interest" and all properties included in the Inventory were transferred to the Register in accordance with the 2005 Amendments to the Ontario Heritage Act.

More than 400 properties had not been subject to a heritage evaluation and still remain on the register as non-designated ("listed") without any heritage score or classification. These properties are prone to unlawful demolition and unsympathetic alteration. There is a need to undertake a comprehensive review to determine if they warrant heritage designation for a greater degree of protection. This is also a good opportunity to reorganize the register by screening out the irrelevant properties that have no heritage value to the community. This will result in a more effective register to assist the Town in managing the protection of its heritage resources.

2.0 PROJECT OVERVIEW

The Town is requesting proposals from a qualified Consultant to conduct a comprehensive review of the Aurora Register of Properties of Cultural Heritage Value or Interest to ensure it maintains an accurate and informative inventory of the Town's heritage resources. The key objectives of the project includes:

Draft Terms of Reference
Review of Aurora Register of Properties of Cultural Heritage Value or Interest

- Determining the level of heritage importance of each listed property on the register in order to prioritize future conservation efforts and preservation programs.
- Identifying those properties of significant cultural heritage value and pursue designation for their long-term protection under the Ontario Heritage Act.
- Update the register with more complete information, and remove irrelevant properties that have no heritage value to the community

3.0 PROCESS

3.1 Phase 1 - Data Collection

Conduct comprehensive research from various sources to fully understand the historical and heritage context of each listed property on the Town's heritage register. The data gathered will be used to inform the preparation of the subsequent heritage evaluation, and also be documented in the municipal archive for the Town's references. The source of the data may include (but not limited to):

- Title Search;
- Field investigation;
- Tax Assessment Records;
- Archival Research (Aurora Historical Society);
- Municipal government documents; and
- Relevant published sources

3.2 Phase 2- Cultural Heritage Evaluation Report (CHER)

Prepare a Cultural Heritage Evaluation Report (CHER) for each listed property to assess its heritage value and recommend the appropriate level of protection required (i.e. designation or documentation). The CHER will include the following information:

- site plan or survey, at an appropriate scale, indicating the context in which the heritage resource is situated.
- A location map with indications of existing land use, zoning, as well as the zoning and land use of adjacent properties.

Draft Terms of Reference
Review of Aurora Register of Properties of Cultural Heritage Value or Interest

- A detailed site history to include a listing of owners from the Land Registry Office, and a history of the site use(s).
- Current legible photographs from each elevation to capture architectural features and building materials.
- Historical photos, drawings, or other archival material that may be available or Relevant.
- Description of all the heritage resources on the subject property which include, but are not limited to: structures, buildings, building elements (like fences and gates), building materials, architectural and interior finishes, natural heritage elements, landscaping, and archaeological resources. The description will also include a chronological history of the structure(s) developments, such as additions, removals, conversions, alterations etc.
- Score each property based on the guidelines outlined in the Town's document titled *Evaluation of Heritage Resources in the Town of Aurora (March 2010)*. Depending on the score, the property will be categorized under one of the priority groups to help determine its level of heritage significance.
- A recommendation as to whether the subject property is worthy of heritage designation in accordance with the criteria per Ontario Regulation 9/06. Should the consultant support heritage designation, it must include the statement of cultural heritage value and description of heritage attributes.

3.2.1 Deliverables for Phase 2

The Consultant will provide the following deliverables to the satisfaction of the Planning Division at a time defined in the approved work plan. All printed materials shall be fully reproducible and all deliverables shall become the absolute property of the Town of Aurora including data developed throughout the process.

- One (1) hard copy of the Cultural Heritage Evaluation Report (CHER) prepared for each property.
- One (1) hard copy of a document summarizing the key findings of each property such as: a brief description of the existing building or structure including its construction date, its heritage score based on the Town's evaluation guidelines, recommendation as to whether it meets the criteria of Ontario Regulation 9/06 for designation, and details of heritage attribute, if applicable.

Draft Terms of Reference
Review of Aurora Register of Properties of Cultural Heritage Value or Interest

- A list of properties recommended to be individually designated under the Ontario Heritage Act; and delisted from the Town's register.
- Electronic copy of all the above documents, preferably in Microsoft Word and PDF format.

3.3 Phase 3 – Consultation with Heritage Advisory Committee and Council

An interim staff report containing a summary of the findings will be brought to the Heritage Advisory Committee and Town Council for information. The Consultant will be expected to attend all the necessary meetings to discuss the recommendations.

3.4 Phase 4 – Heritage Designation, Delisting and Update to the Register

Staff will work with the Consultant to address any comments made by the Heritage Advisory Committee and Town Council, which may include re-examining particular properties and carrying out further heritage investigation.

A second staff report will be presented to the Heritage Advisory Committee and Council to recommend the final list of properties to be designated for long-term protection, and delisted from the Aurora Register of Properties of Cultural Heritage Value or Interest, for the Heritage Committee and Council's consideration. Following Council's decision, the Town will proceed to designate the appropriate properties in accordance with the requirements of the Ontario Heritage Act. The irrelevant properties will be removed from the Town's heritage register.

The consultant will develop a new template for the Town's register to include additional details about each property as required under Section 27 (1.1) of the Ontario Heritage Act and Section 13.3 b) of the Town's Official Plan, which includes legal description, owner information, statement of cultural heritage value, description of heritage attributes and designation by-law number. Listed properties only requires a brief description about their heritage resource.

3.4.1 Deliverables for Phase 4

The Consultant will provide the following deliverables to the satisfaction of the Planning Division at a time defined in the approved work plan. All printed materials shall be fully reproducible and all deliverables shall become the absolute property of the Town.

Draft Terms of Reference
Review of Aurora Register of Properties of Cultural Heritage Value or Interest

- One (1) hard copy of an updated register in a new template including all the additional information listed in Section 3.4
- Electronic copy of all the document, preferably in both Microsoft Word and PDF format

4.0 TIMING

The estimated timeline for completing the study has not been determined, but it is estimated that the study will take a minimum of one year to complete, from when the consultant team begins work on the project to Council's approval of the recommendations of the CHERs. Through the request for proposal (RFP) process, consultants will be asked to identify opportunities for efficiencies while still meeting the requirements of the terms of reference and all applicable requirements.

5.0 ROLES AND RESPONSIBILITIES

5.1 Steering Committee

A five (5) person Steering Committee is being proposed by Staff to provide direction, guidance and recommendations on the project. Staff are recommending that the Committee be comprised of three (3) members of the Heritage Advisory Committee and two (2) members from Town Council. The number of meetings required will be determined by Town Staff and the retained consultant. It is not anticipated that more than five (5) to ten (1) meetings will be required over the course of the project.

5.2 Town Staff (Planning Division)

- Provide supporting documents and information as required by the Consultant
- Prepare staff report for the Heritage Committee and Council's consideration
- Attend Committee and Council Meetings

5.3 Consultant

- Conduct all historical research associated with the project
- Prepare a Cultural Heritage Evaluation Report for each listed property based on the parameters set out in the Terms of Reference

Draft Terms of Reference
Review of Aurora Register of Properties of Cultural Heritage Value or Interest

- Provides the Planning division an update of the project on a bi-monthly basis
- Attend Committee and Council Meetings
- Develop a new template for the Town's register to include additional information outlined in Section 3.4

6.0 REQUEST FOR PROPOSAL

6.1 Required Proposal Format

In order to receive consistent format of information from all prospective consulting firms the following should be addressed in the proposal:

- Proposals should be submitted electronically only in PDF format (less than 15 MB in size) including a letter of submission signed by an authorized representative of the Consultant.
- Proposals must outline the cost of completing the project listed in the Terms of Reference both as a total price, total plus HST and by a cost per task format. The consultant shall identify sub-consultants, if required, and their fees. These cost shall be paid for and supervised by the consultant.
- The proposal shall include a Work Plan and the expected time frame for the completion of the project
- The Proposal will include a summary of the Consultant's professional information and relevant experience.
- A summary of past projects which will demonstrate the Consultant's experience in the study tasks as outlined in the terms of reference.
- Proposals must be submitted with a minimum of three references listed for contact respecting recent and relevant projects.

6.2 Interviews

Consultants may be asked to attend an interview prior to a final decision.

Draft Terms of Reference
Review of Aurora Register of Properties of Cultural Heritage Value or Interest

6.3 Selection and Awarding of Contract

The appointment of the successful consultant shall be in accordance with a selection process carried out by Town Staff, with Council authorizing final selection, if required. Consultants are advised that the lowest cost proposal will not be necessarily be awarded the contract, as the selection will be based on the following criteria and cost is only one of the criteria.

- The degree to which the proposal responded to the RFP and Terms of Reference.
- The demonstration of relevant experience in similar studies and the professional reputation of the consultants.
- The demonstrated ability of the consultant to provide the services.
- The total cost and timing of the project

6.4 Submission Deadline

The proposal shall be submitted to the Town of Aurora via email at Planning@aurora.ca by 4:30 p.m. on xxxxxx, 2020 (to be determined). Proposals received after this date and time will not be considered.



100 John West Way
Box 1000
Aurora, Ontario
L4G 6J1
Phone: 905-727-3123 ext. 4349
Email: ctsang@aurora.ca
www.aurora.ca

**Town of Aurora
Planning and Development
Services**

Memorandum

Date: February 3, 2020
To: Heritage Advisory Committee
From: Carlson Tsang, Planner
Copy: David Waters, Director of Planning and Development Services
Re: **Alterations to a Listed Heritage Property – 46 Mosley Street**

Recommendation

- 1. That the memorandum regarding Alterations to a Listed Heritage Property – 46 Mosley Street be received for information.**

Purpose

The purpose of this memorandum is to inform the Heritage Advisory Committee about a building permit application for alteration to an existing dwelling known as “The Wallace House” at 46 Mosley Street, which is a non-designated property listed on the Town’s Heritage Register. While the proposed work does not require a heritage permit under the Ontario Heritage Act, the subject property may become designated in the future and therefore the application is being presented to the Heritage Advisory Committee for information prior to the issuance of a building permit by the Town.

Background

Property Description

46 Mosley Street is located on the north side of Mosley Street, south of Wellington Street East and east of Yonge Street. The property contains a two-storey detached dwelling known as “The Wallace House” constructed circa 1867 and a detached garage in the rear yard. The building is characterized by multiple gable roofs, multi-paned sash windows, and board and batten siding. The front elevation features an enclosed porch with a balcony above. The gable roof directly above the balcony entrance contains a decorative bargeboard. There is a one-storey addition located at the rear of the building.

Alterations to a Listed Heritage Property – 46 Mosley Street
February 3, 2020

Page 2 of 2

Ontario Heritage Act

46 Mosley Street is a non-designated property listed on the Town's heritage register, which means it has been identified by Council as being of potential cultural heritage value or interest. It is subject to interim protection under Section 27 (3) of the *Ontario Heritage Act* where the owner is required to provide the Town at least 60-days' notice in writing of their intention to demolish or remove a building or structure on the property. However, alterations to the building or structure on the property would not require approval of a heritage permit under the *Ontario Heritage Act*.

Building Permit PR20190319

On December 9, 2019, the Town received a building permit application (PR20191319) to allow various changes to the building including:

- Construct a second-storey bedroom above the existing addition at the rear of the dwelling. The proposed work includes installing a new foundation wall and undertaking structural improvements to the existing rear addition in order to accommodate the new addition. The proposed addition will be entirely contained within the existing building footprint.
- Modifications to the front elevation such as adding two new windows on the second floor, converting the balcony entrance into a window, eliminating the balcony and reconfiguring the front covered porch.
- Redesign the roof of the main building to align with the proposed rear addition.
- Replace existing sidings of the building with board and batten.
- Upgrade the detached garage by installing new doors and a new roof with decorative dormers.

Attachments

Attachment 1 – Location Map

Attachment 2 – Drawings for Building Permit PR20190319

Attachment 3 – Heritage Resource Brief

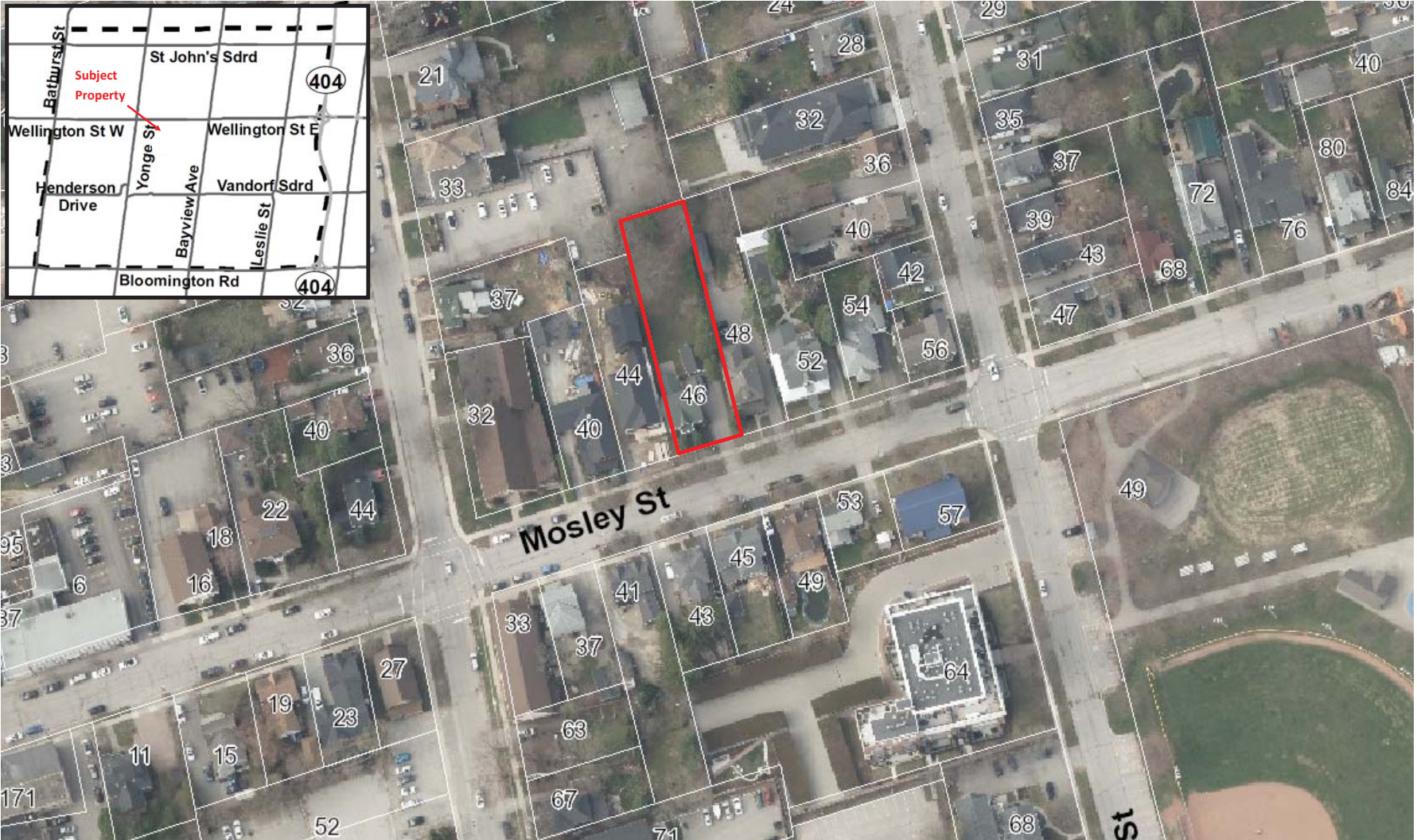

LOCATION MAP

APPLICANT: Daniel Filgno
 LOCATION: 46 Mosley Street
 FILE: PR20191319
 ATTACHMENT 1

 **SUBJECT LANDS**

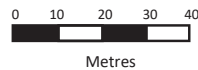

Map created by the Town of Aurora Planning and Building Services Department, January 2020. Base data provided by York Region & the Town of Aurora. Air Photos taken Spring 2018, © First Base Solutions Inc., 2018 Orthophotography.

Attachment 2

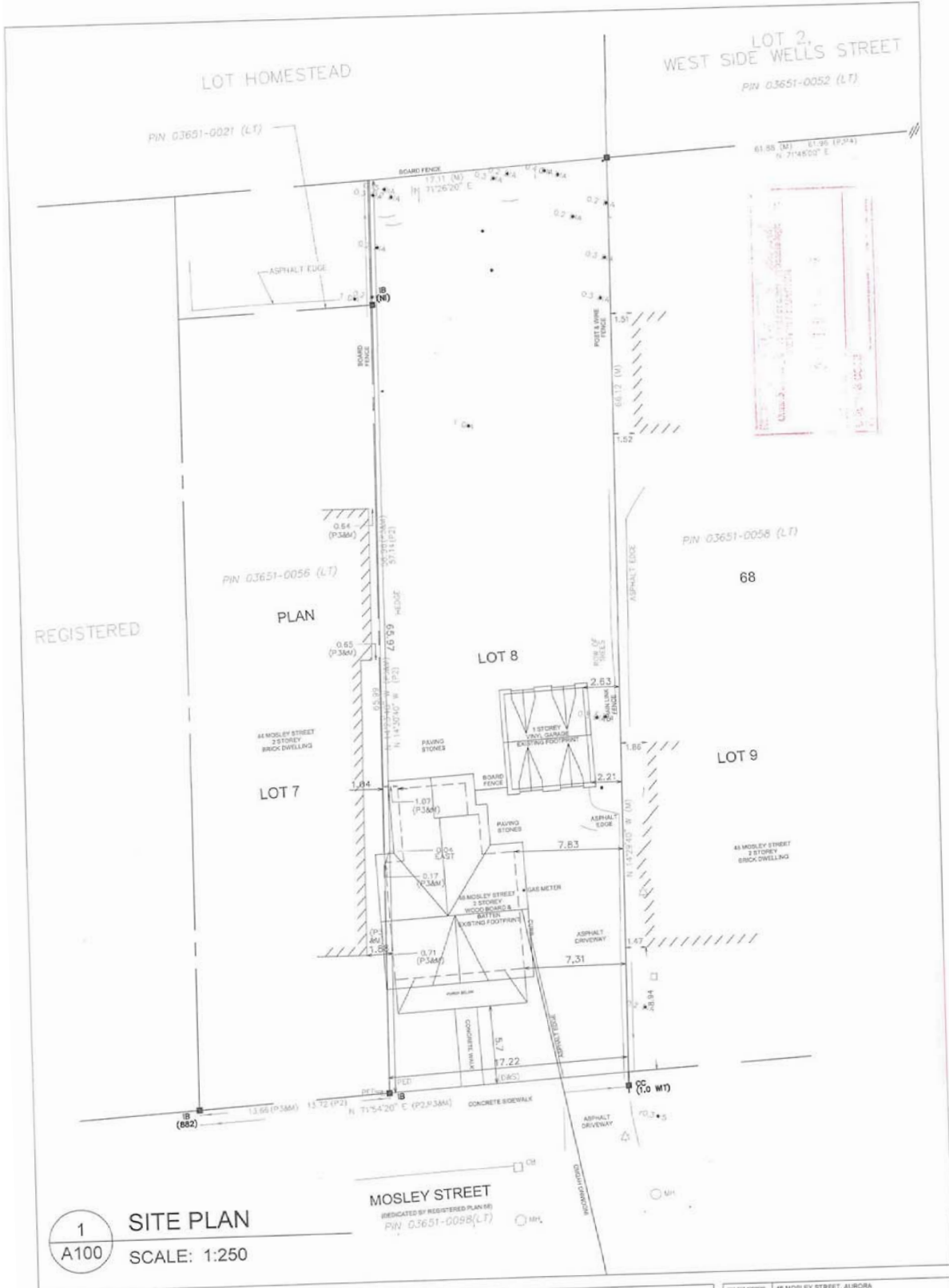

1
 A100
SITE PLAN
 SCALE: 1:250

DATE	DESCRIPTION

DESIGNER INFORMATION:	
DATE: 2018-12-09	DESIGNER: DANIEL FELIGNO
PROJECT: 44 MOSLEY STREET, AURORA	REGISTERED PLAN: MOSLEY
DATE: 2018-12-09	DRAWN BY: DANIEL FELIGNO

ASSEMBLIES	

PROJECT ADDRESS: 44 MOSLEY STREET, AURORA	
PROJECT NAME: MOSLEY	DATE: 2018-12-09
DATE: 2018-12-09	DRAWN BY: DANIEL FELIGNO
DRAWN BY: DANIEL FELIGNO	
A100	

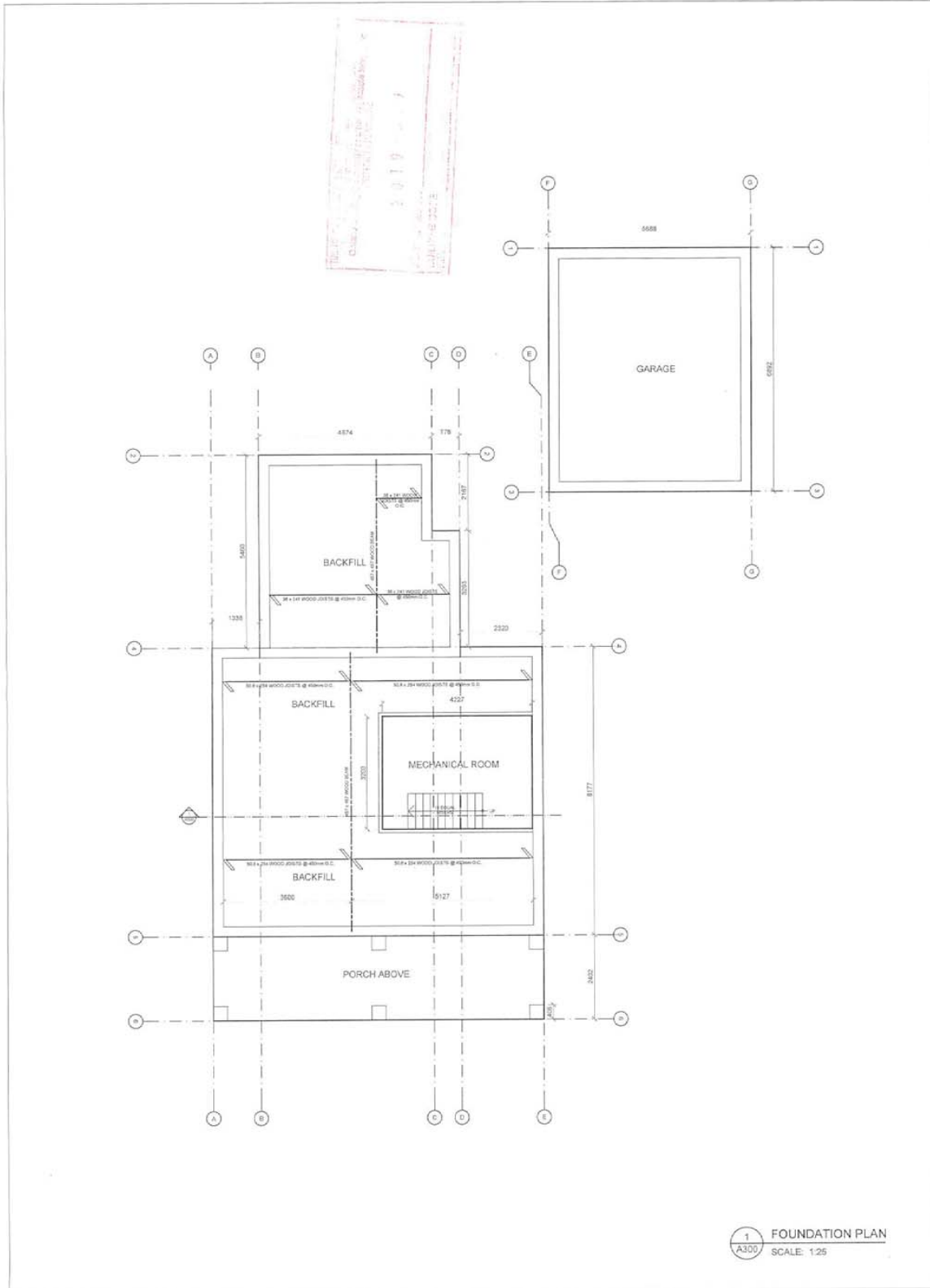

NO.	DATE/ISSUE	ISSUED FOR

DESIGNER INFORMATION:
 Daniel Filigno
 45 Mosley Street, Aurora
 630-833-4888

FOUNDATION PLAN

PROJECT ADDRESS:	45 MOSLEY STREET, AURORA
PROJECT NAME:	MOSLEY
SCALE:	1:100
DATE:	2015-12-09
DESIGNER:	DANIEL FILIGNO
DRAWING NUMBER:	A300

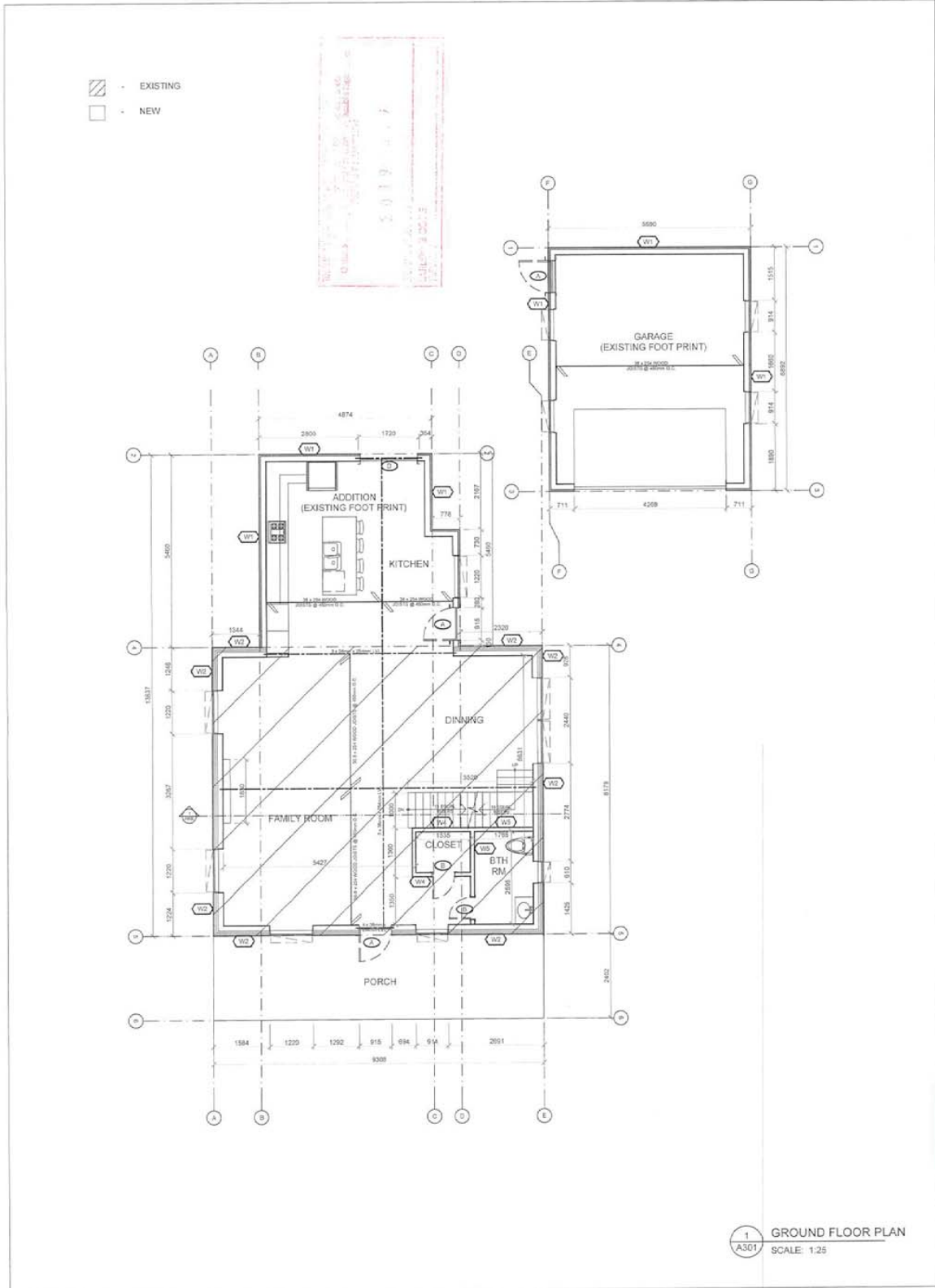

REV	DATE	DESCRIPTION

DESIGNER INFORMATION:
 Daniel Filigno
 46 Wosley Street
 Aurora, IL 60009
 708.588.4888

GROUND FLOOR PLAN

PROJECT ADDRESS	46 WOSLEY STREET, AURORA
PROJECT NAME	WOSLEY
SCALE	1:100
DATE	2019-12-09
DRAWN BY	DANIEL FILIGNO
DRAWING NUMBER	A301

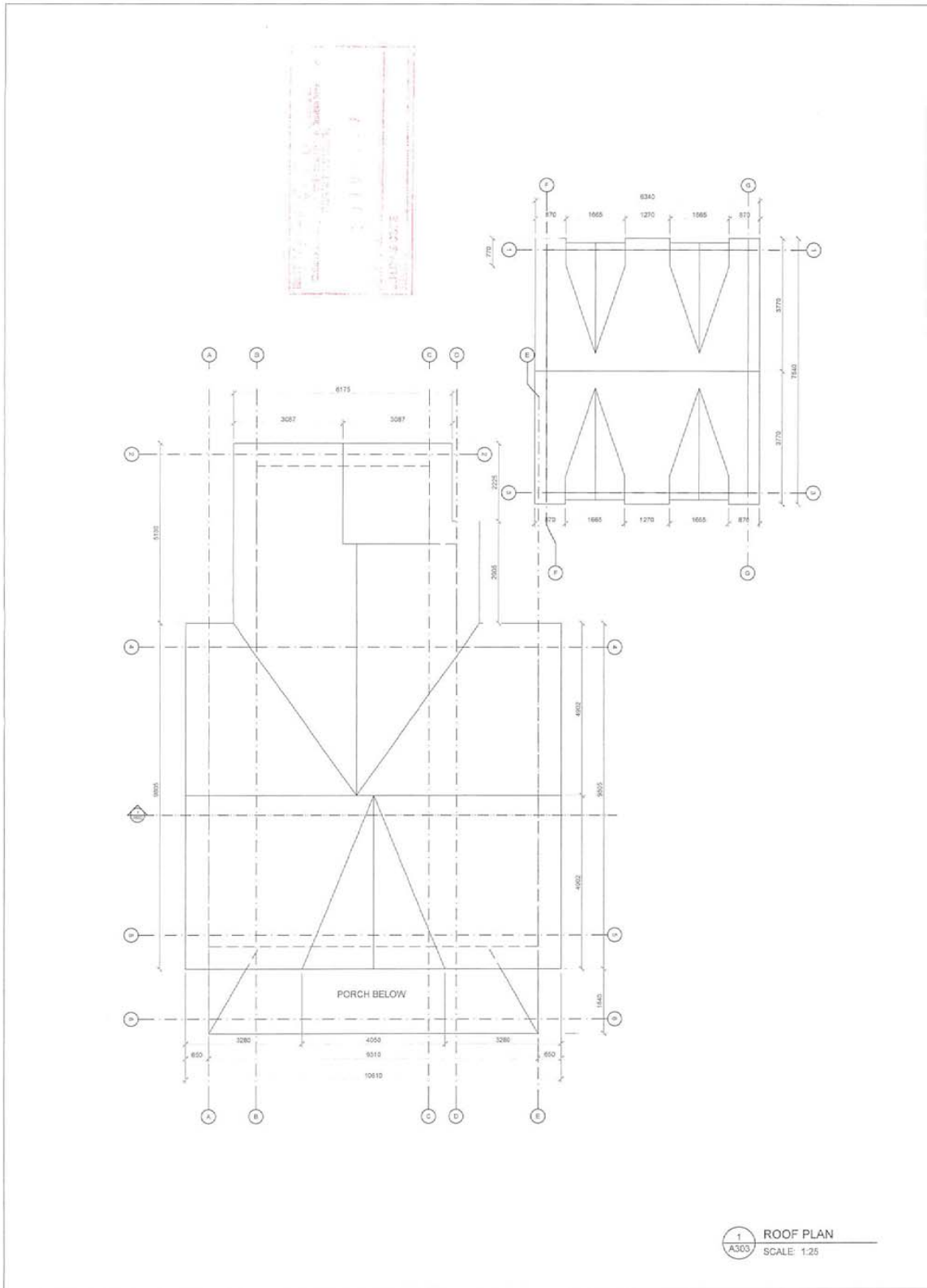

1 ROOF PLAN
A303 SCALE: 1:25

NO.	DATE	REVISION

DESIGNER INFORMATION:
 Daniel Filigno
 811 Cambridge Court
 Mendota, WI
 53181-4000

ROOF PLAN

PROJECT ADDRESS	46 MOSLEY STREET, AURORA
PROJECT NAME	MOSLEY
SCALE	1:150
DATE	2019-12-09
DRAWN BY	DANIEL FILIGNO
CHECKED/DATE	
A303	

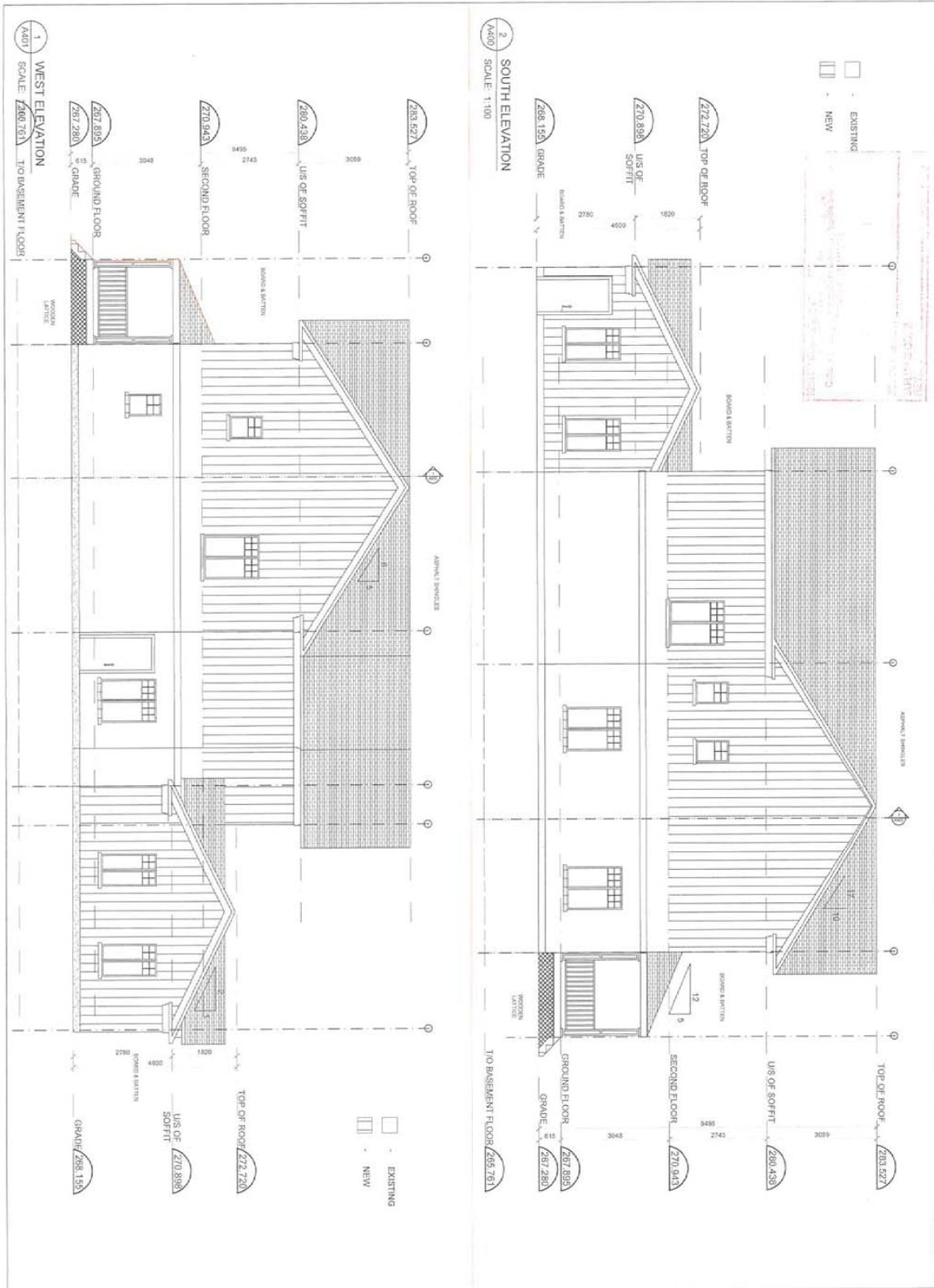

REV	DATE	BY	DESCRIPTION

DESIGNER INFORMATION:
 Daniel Filigno
 11000 15th Avenue South
 Suite 100
 Aurora, CO 80015
 303.688.4422

ELEVATIONS - EAST/WEST

PROJECT NUMBER:	46 MOSLEY STREET, AURORA
PROJECT NAME:	MOSLEY
SCALE:	1:100
DATE:	2019-12-09
DRAWN BY:	DANIEL FILIGNO
CHECKED BY:	
A401	

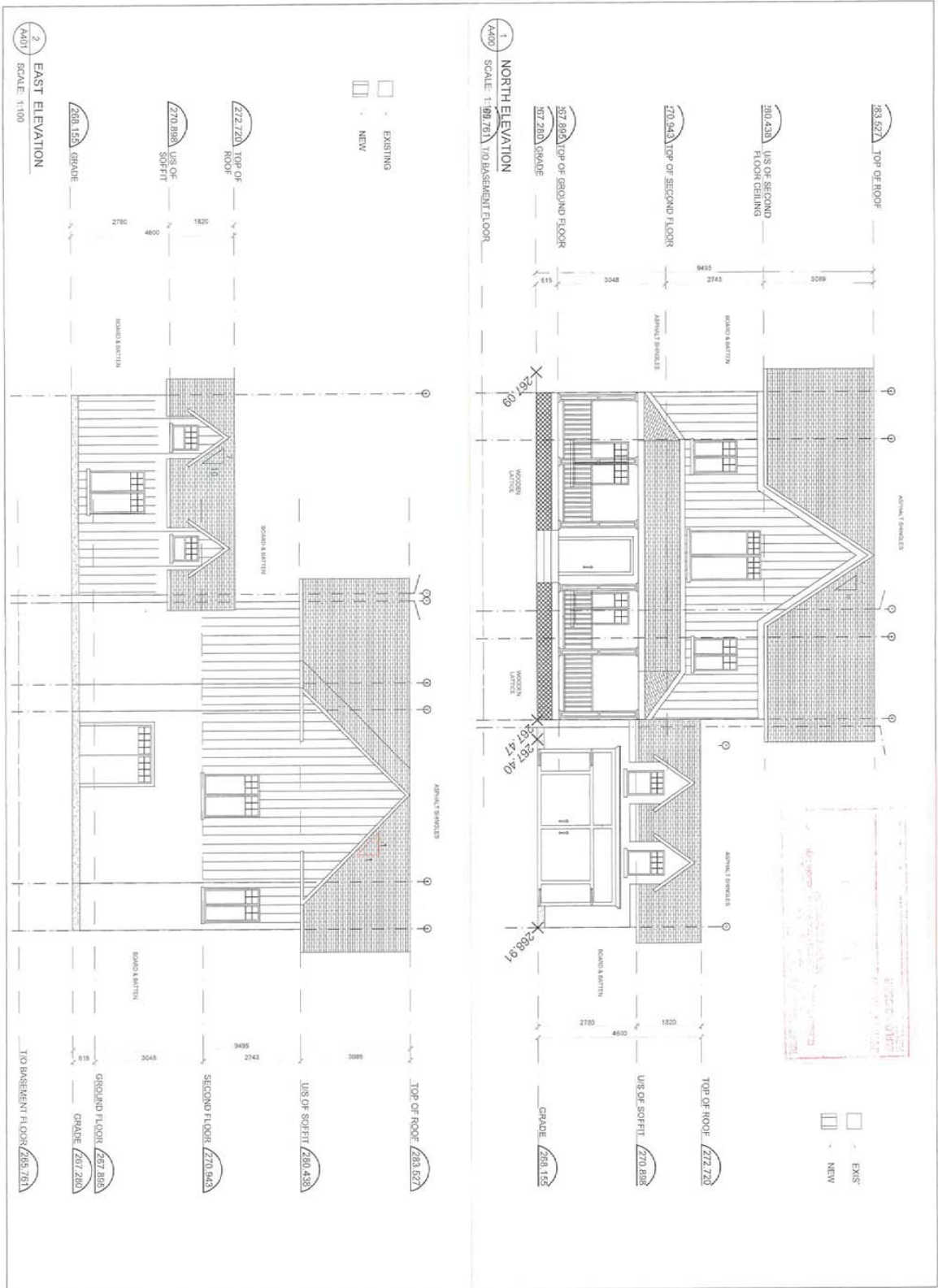

2 EAST ELEVATION
SCALE: 1/4"=1'-0"

1 NORTH ELEVATION
SCALE: 1/8"=1'-0"

REV	DATE	DESCRIPTION

DESIGNER INFORMATION:
 Dan Mosley
 1000 Lakeshore Blvd. East
 Aurora, ON L4G 1W4
 416-292-4004

ELEVATIONS - NORTH/SOUTH

PROJECT ADDRESS	46 MOSLEY STREET, AURORA
PROJECT NAME	MOSLEY
SCALE	1/4"=1'-0"
DATE	2018-12-09
DRAWN BY	DANIEL FILIAGO
DESIGNED BY	
A400	

**AURORA REGISTER OF PROPERTIES OF CULTURAL
HERITAGE VALUE OR INTEREST (Updated 2017)**

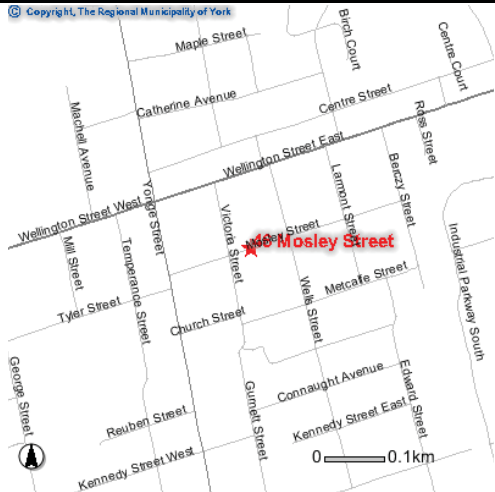
<p>SITE</p>	<p>Address: 46 Mosley Street Former Address: Legal Description: PLAN: 68 PART LOTS: 7, 8</p>
<p>STATUS</p>	<p>Current Use: Residence Original use: Residence Heritage Status: Listed & Undesignated By-law No. & Date: Official Plan: Stable Neighbourhood Residential Zoning: R7 (Special mixed density) HCD: Plaques: Wooden plaque (1995/96/97)</p>
<p>PHOTOGRAPH</p>	
<p>KEY MAP</p>	

**AURORA REGISTER OF PROPERTIES OF CULTURAL
HERITAGE VALUE OR INTEREST (Updated 2017)**

ARCHITECTURE

GENERAL INFORMATION:

Address:	46 Mosley Street	Builder:	
Construction Date:	c1867	Architect:	
Architectural Style:	Ontario House	Original Owner:	
Heritage Easement:		Historical Name:	The Wallace House

GENERAL DESCRIPTION:

Floor Plan:		Storey:	1 ½
Foundation Materials:			
Exterior Wall Materials:			
Roof Type:	Gable; centre gable with door; returned eaves	Windows:	
Entrance:	Transom	Bays:	

UNIQUE FEATURES:

Chimney (s):		Special Windows:	
Dormers:		Porch/Verandah:	Enclosed porch with balcony
Roof Trim:	Wood	Door Trim:	
Window Trim:		Other:	Aluminum siding

HISTORY

Historical Society files include:

Town of Aurora files include:

PHOTOS:

HISTORICAL PHOTO	INVENTORY PHOTO
Photo date	Photo date

The Aurora Inventory of Heritage Buildings was compiled by the Aurora Heritage Advisory Committee (LACAC) between 1976 and 1981. The completed inventory was adopted by Council and released in 1981. On September 26, 2006 Aurora Council at its meeting No. 06-25, has officially changed the name of the Aurora Inventory of Heritage Building to the **"Aurora Register of Property of Cultural Heritage Value or Interest"** and all property included in the Inventory were transferred to the Register.