



**NOTICE OF PUBLIC HEARING  
MINOR VARIANCE**

**Pursuant to Section 45(5) of *The Planning Act***

**FILE NUMBER:** MV-2023-39

**APPLICANT:** MICHAEL TOBIN AND ROSEMARY TOBIN

**PROPERTY:** 38 Marsh Harbour, Aurora, ON L4G5Y6  
PLAN 65M2358 LOT 40

**RELATED  
APPLICATIONS:** n/a

**ZONING:** R2 Detached Second Density Residential

**PURPOSE:** A Minor Variance Application has been submitted to facilitate a shed.

**THE FOLLOWING  
VARIANCES ARE  
REQUIRED:**

- 1) Section 7.2 of the Zoning By-law requires a minimum side yard setback of 1.2m
  - a. The applicant is proposing a shed, which is 0.41m to the side lot line.
- 2) Section 4.1.1 of the Zoning By-law requires a minimum rear yard of 1m for an accessory structure.
  - a. The applicant is proposing a shed, which is 0.43m to the rear lot line.
- 3) Section 4.12.2(b) of the Zoning By-law requires a minimum distance separation of 1.2 metres from the nearest of the water contained in the pool shall be maintained from all buildings and/or structures.
  - a. The applicant is proposing a shed, which is 0.97m to the water's edge.

A Location Map and Site Plan illustrating the request are attached. This Application will be heard by the Committee of Adjustment on the Date and Time shown below.

<b>DATE:</b>	<b>February 8, 2024</b>
<b>TIME:</b>	<b>7:00 p.m.</b>
<b>LOCATION:</b>	<b>Electronic Meeting (Please visit <a href="https://www.youtube.com/user/Townofaurora2012">https://www.youtube.com/user/Townofaurora2012</a> for live stream of the meeting)</b>

**NOTE:** The Committee of Adjustment meetings will be held electronically and may be viewed via live stream. Please visit the Town’s website for further details.

You may express your views about this Application, for consideration by the Committee, in the following ways:

- i) **Participate in the electronic meeting as a live delegate.** Please send a delegation request to the Secretary-Treasurer, Peter Fan, at [PFan@aurora.ca](mailto:PFan@aurora.ca) **no later than 4:30pm on February 6<sup>th</sup>, 2024.** Once the request has been received, instructions will be provided on how to make your delegation during the electronic meeting.

The Delegation Request form is located on the Town website: <https://webforms.aurora.ca/Your-Government/Committee-of-Adjustment-Delegation-Request-Form>

- ii) **Provide written comments.** Please email your comments to the Secretary-Treasurer, Peter Fan, at [Pfan@aurora.ca](mailto:Pfan@aurora.ca) **no later than 12:00pm (noon) on February 8<sup>th</sup>, 2024.** **Alternatively, comments may be mailed to Town Hall** at the address below. Please note, mailed comments must be received by the Town prior to the meeting in order to be considered by the Committee.

*Town of Aurora*  
100 John West Way, Box 1000  
Aurora, ON L4G 6J1

If you wish to be notified of the Decision with respect to this Application, you must complete the enclosed “Request for Decision” form. The form can also be found at <https://www.aurora.ca/en/business-and-development/resources/development->

[planning/Committee-of-Adjustment/Request-for-Decision--Fillable.pdf](#). This form is to be emailed to [PFan@aurora.ca](mailto:PFan@aurora.ca) no later than 4:30pm on February 8<sup>th</sup>, 2024.

**If you receive this notice as an owner of land containing seven or more residential units, please post this notice in a location that is visible to all property residents.**

Should you have any questions regarding this application, please contact Peter Fan at [PFan@aurora.ca](mailto:PFan@aurora.ca) or at **(905) 726-4711**

#### **Personal Information Collection Notice**

Your personal information and your comments are collected under the legal authority of the *Planning Act, R.S.O. 1990, Chapter c.P.13*, as amended. Your comments in respect to this Application will become part of the decision-making process of the Application as noted on this form. Pursuant to Section 27 of the *Municipal Freedom of Information and Protection of Privacy Act, R.S.O. 1990, c. M.56*, as amended, (the "Act") public feedback to planning proposals is considered to be a public record and may be disclosed to any individual upon request in accordance with *the Act*. Questions about this collection should be directed to the Town Clerk, Town of Aurora, 100 John West Way, Box 1000, Aurora ON L4G 6J1 905-727-3123.

DATED THIS 25<sup>th</sup> DAY OF January 2024



Peter Fan  
Secretary-Treasurer/Assistant Planner  
Committee of Adjustment

#### **ATTACHMENTS**

- Attachment 1 – Location Map
- Attachment 2 – Site Plan
- Attachment 3 – Request for Decision

**Agenda packages will be available prior to the Hearing at:**

<https://www.aurora.ca/agendas>

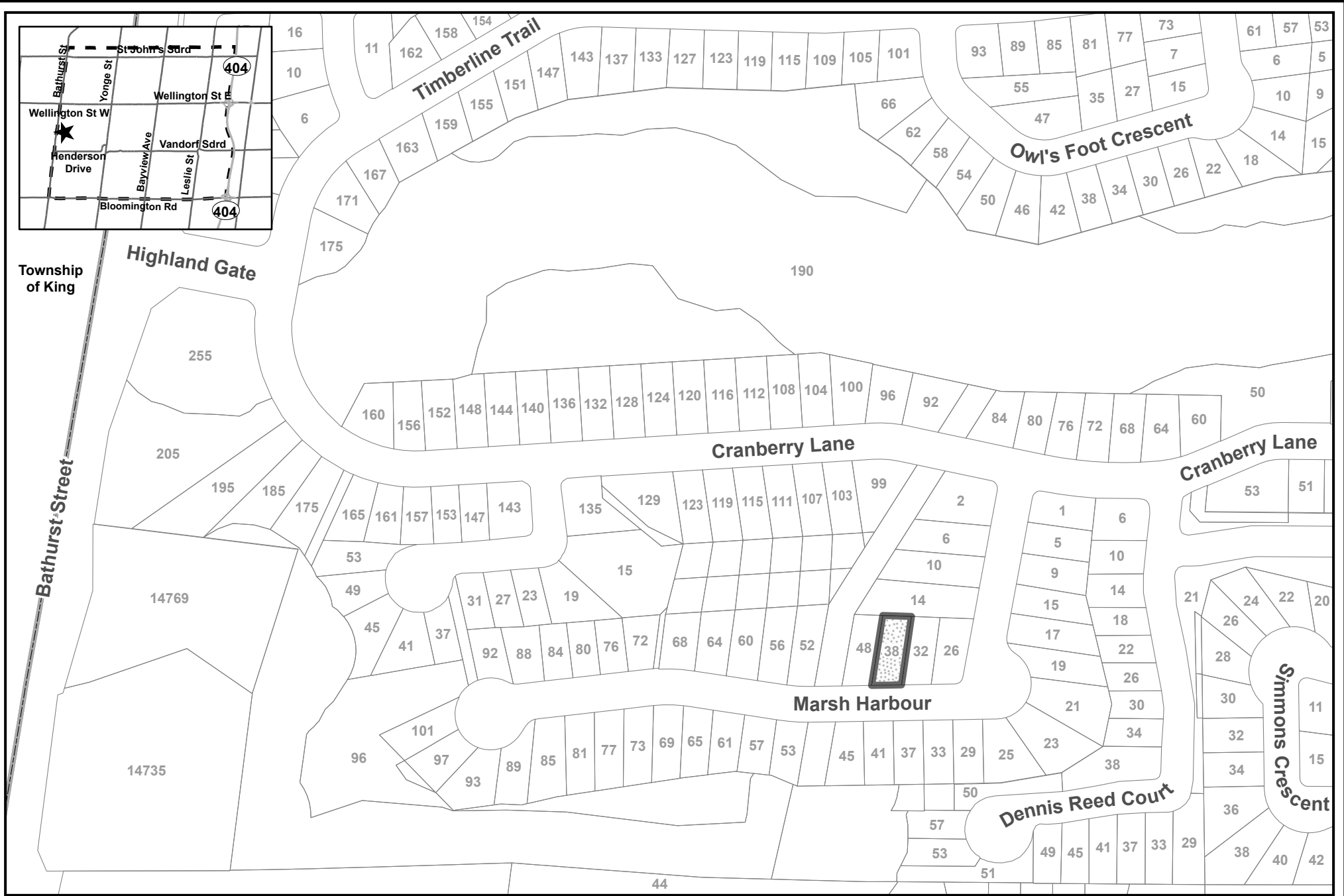

**LOCATION MAP**  
**38 MARSH HARBOUR**  
**FILE: MV-2023-39**  
**TOWN OF AURORA**  
**COMMITTEE OF ADJUSTMENT**

 **SUBJECT LANDS**

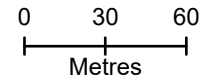

BUILDING LOCATION SURVEY OF  
 LOTS 40 AND 41, PLAN 65M-2358  
 TOWN OF AURORA  
 REGIONAL MUNICIPALITY OF YORK

center horwood limited, ontario land surveyors - 1986

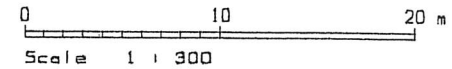

METRIC :  
 Distances shown on this plan are in metres and  
 can be converted to feet by dividing by 0.3048

LEGEND  
 ■ Survey Monument Found  
 □ Survey Monument Set  
 SIB Standard Iron Bar  
 IB Iron Bar  
 CH Carter Horwood Limited

BEARING NOTE  
 Bearings are astronomic, derived from Plan  
 65M-2358.

SURVEYOR'S CERTIFICATE

I certify that :

The field survey represented by this plan was  
 completed on the 30th day of September, 1986.

October 1, 1986

*Edward C. Carter*  
 Edward C. Carter  
 Ontario Land Surveyor

Project No. 1910

475-7265 / 294-1328

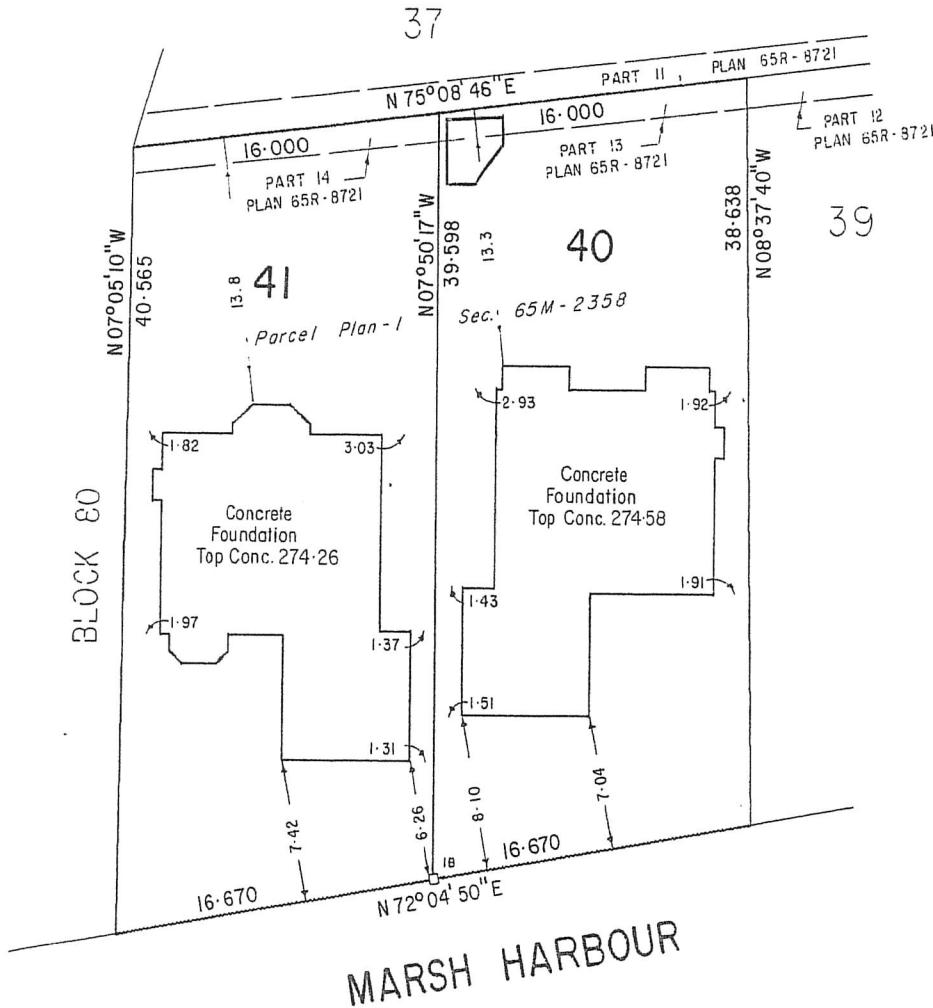

TOWN OF AURORA  
 PLANNING & DEVELOPMENT SERVICES  
 BUILDING DIVISION  
 PERMIT NO.: PR20231319 DATE: Oct. 19, 2023  
 APPROVED BY: *Shawn Shuman*  
 PRELIMINARY ZONING REVIEW

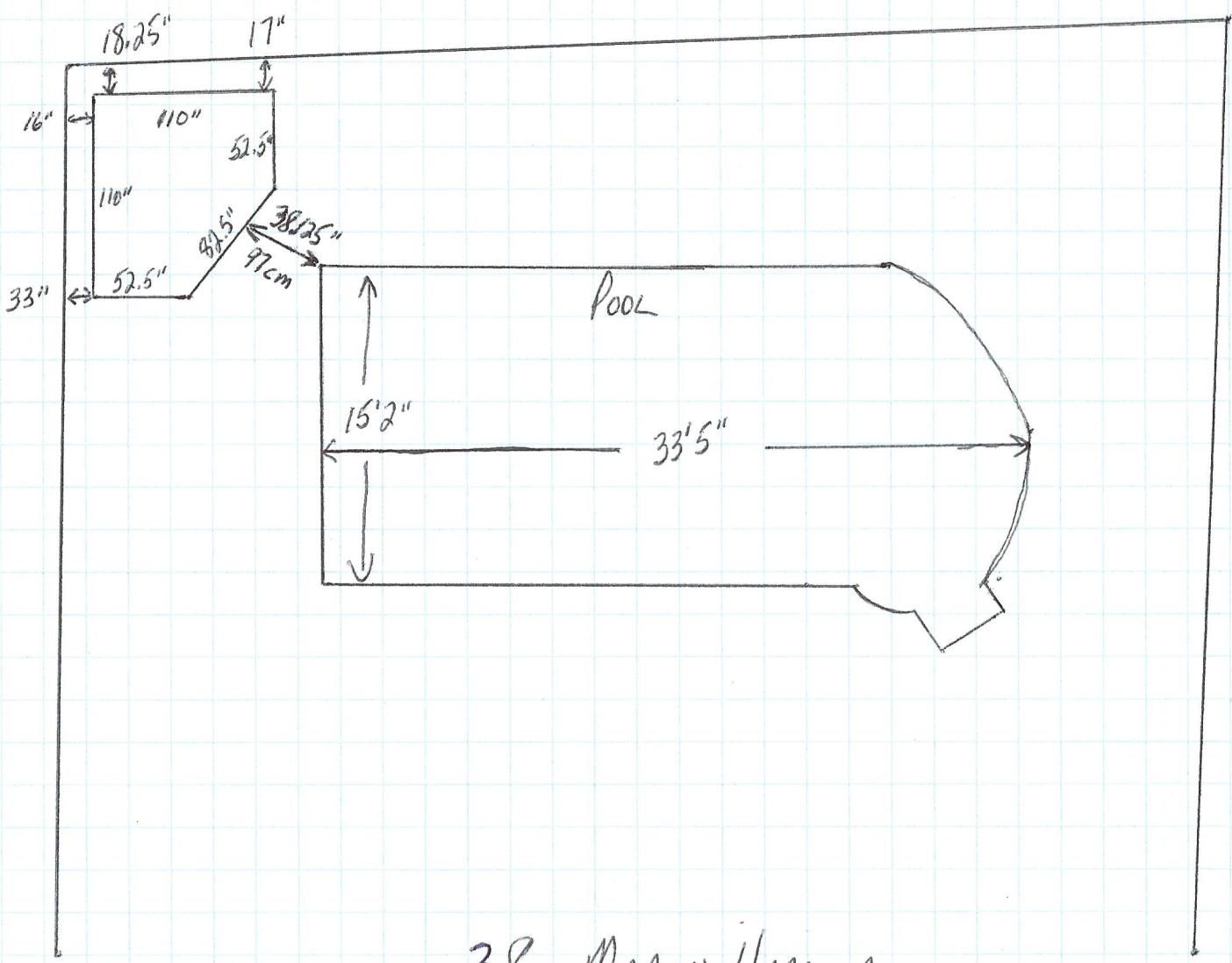

SHED IS:

HEIGHT: 120"

WALL HEIGHT: 76.5"

38 MARSH HARBOUR

ALL MEASUREMENTS ARE  
IN FEET OR INCHES

TOWN OF AURORA  
 PLANNING & DEVELOPMENT SERVICES  
 BUILDING DIVISION  
 PERMIT NO.: PR20231319 DATE: Jan. 16, 2024  
 APPROVED BY: *Diana Shostin*  
 PRELIMINARY ZONING REVIEW

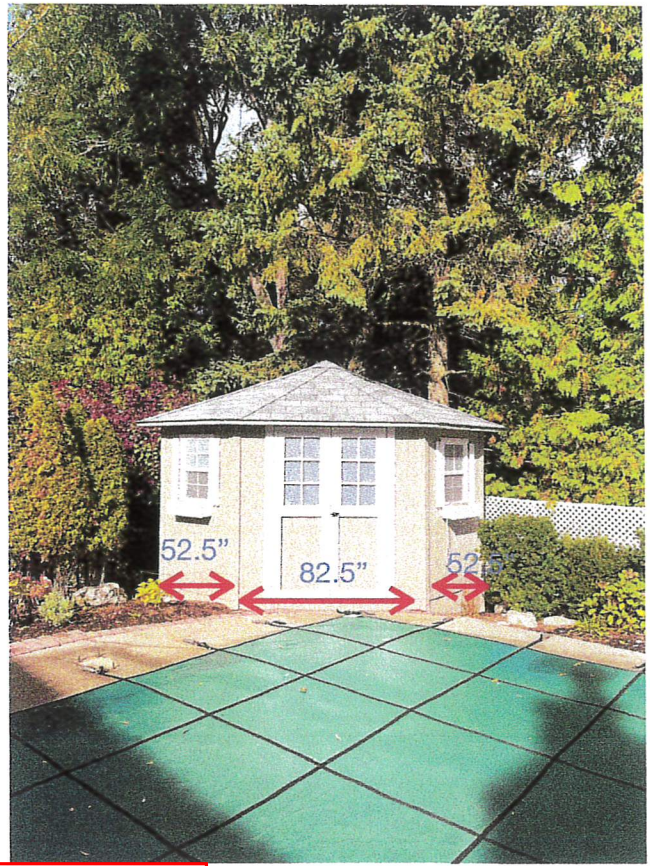

TOWN OF AURORA  
 PLANNING & DEVELOPMENT SERVICES  
 BUILDING DIVISION  
 PERMIT NO.: PR20231319    DATE: Oct. 19, 2023  
 APPROVED BY: *Hana Hussein*  
 PRELIMINARY ZONING REVIEW

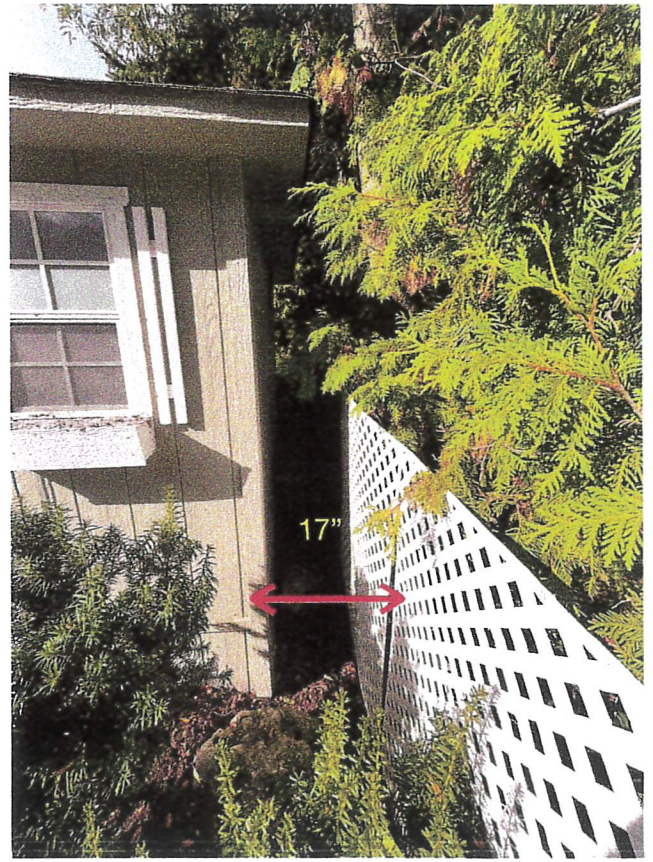
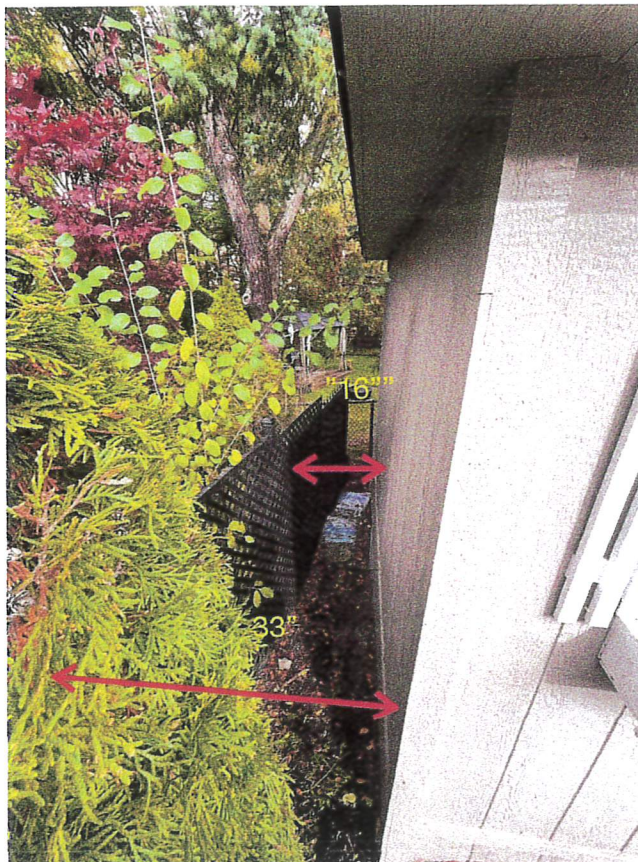



# TOWN OF AURORA COMMITTEE OF ADJUSTMENT REQUEST FOR DECISION

Meeting Date: \_\_\_\_\_ Agenda Item Number: \_\_\_\_\_

Application Name: \_\_\_\_\_

File Number(s): \_\_\_\_\_

## IMPORTANT NOTICE

You must complete this form and submit it to the Secretary-Treasurer to ensure your name and address are accurately noted for future notification.

This meeting is your opportunity to voice any opinions or comments you may have regarding an Application for approval of a Minor Variance/Permission or Consent. Under the *Planning Act*, for a Minor Variance and Permission, Section 45(10) states that the Secretary-Treasurer shall send one copy of the decision, to each person or public body who appeared in person or by counsel at the hearing AND who filed with the Secretary-Treasurer a written request for Notice of the Decision. For Consent, Section 53(17) states that if the Committee gives or refuses to give provisional Consent, the Committee shall ensure written Notice of the Decision is given to each person or public body that made a written request to be notified of decision or conditions.

**NOTE:** Due to COVID-19, all Request for Decisions shall be emailed to Peter Fan, Secretary-Treasurer, at [pfan@aurora.ca](mailto:pfan@aurora.ca).

**Please print clearly and provide information requested below.**

Name: \_\_\_\_\_  
(MR./MRS./MS) (First) (Last)

Address: \_\_\_\_\_  
\_\_\_\_\_

Municipality: \_\_\_\_\_ Postal Code: \_\_\_\_\_  
(Must Be Provided)

Telephone: Residence \_\_\_\_\_ E-Mail: \_\_\_\_\_  
Business \_\_\_\_\_ E-Mail: \_\_\_\_\_

**Notice of Decision and/or future consideration of this Committee of Adjustment Application will be provided by E-Mail.**

**NOTE: Notice of this meeting was given by mail to all owners within 120 metres (400 feet) of the subject lands**

Personal information on this form is collected under the legal authority of the *municipal act*, R.S.O.1990, and C.M.45, as amended. This information will be used for the purposes of sending correspondence relating to matters before council. The information is collected and maintained for the purpose of creating a record that is available to the general public pursuant to section 27 of the *municipal freedom of information and protection of privacy act*, R.S.O. 1990, C.M.56, as amended. Questions about this collection should be directed to the town clerk, town of aurora, 100 john west way, box 1000, aurora, Ontario, l4g 6j1, telephone: 905-727-4771